

High Accuracy Picoammeters For Low Current/High Resistance Applications



KEITHLEY

A GREATER MEASURE OF CONFIDENCE



- Economical, high precision solutions for measuring low currents
- Lower voltage burden ensures greater measurement accuracy
- Higher speed and resolution than any other picoammeters available
- Flexible resistance measurement options

Current Measurement Range

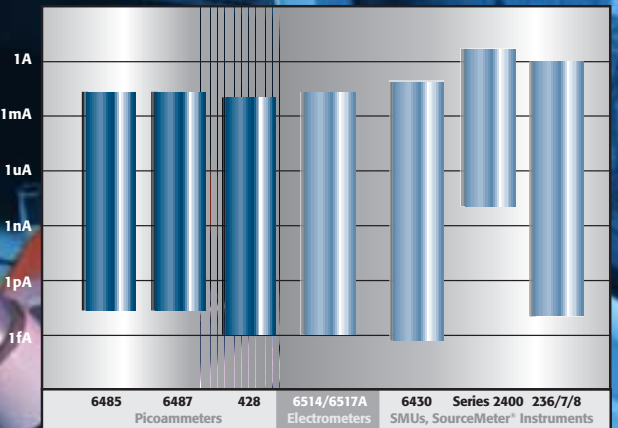

Maximum Bandwidth

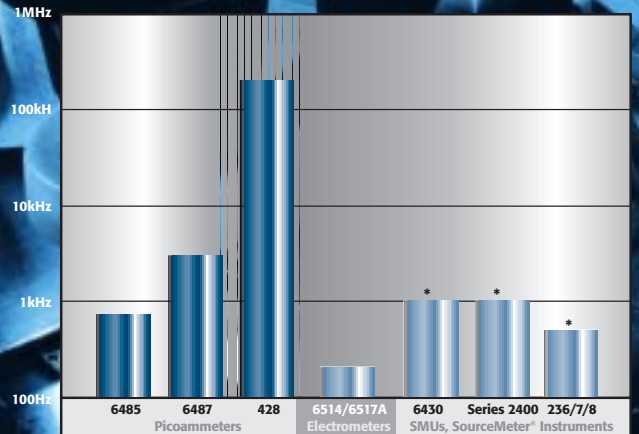

* No analog output; bandwidth set by maximum reading rate

Voltage Sourcing Capability

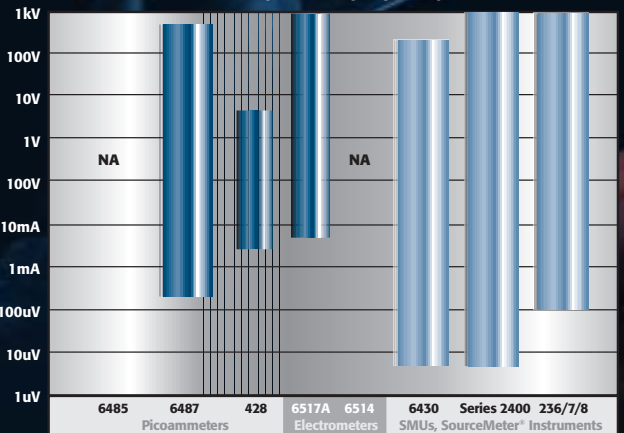

High performance picoammeters

Keithley brings more than half a century of expertise in designing and manufacturing sensitive instrumentation to our new low current measurement solutions. Our picoammeters combine high accuracy with sensitivity as good as 1fA. They have always provided exceptional voltage burden specifications and wide measurement ranges; our newest instruments offer higher measurement speeds than ever before.

What is a picoammeter?

Measuring low DC currents often demands a lot more than a digital multimeter can deliver. Generally, DMMs lack the sensitivity required to measure currents less than 100nA. Even at higher currents, a DMM's input voltage drop (voltage burden) of hundreds of millivolts can make accurate current measurements impossible. Electrometers can measure low currents very accurately, but the circuitry needed to measure extremely low currents, combined with functions like voltage, resistance, and charge measurement, can increase an electrometer's cost significantly. Keithley's line of picoammeters combines the economy and ease of use of a DMM with low current sensitivity near that of an electrometer.

Why is low voltage burden critical?

Voltage burden is the voltage that appears across the ammeter input terminals when measuring. As *Figure 1* illustrates, a DMM uses a shunt ammeter that requires voltage (typically 200mV) to be developed across a shunt resistor in order to measure current. This voltage burden will reduce the actual current flowing in the circuit, and reduce accuracy. A picoammeter uses a feedback ammeter to reduce this terminal voltage by several orders of magnitude (*Figure 2*).

Figure 1

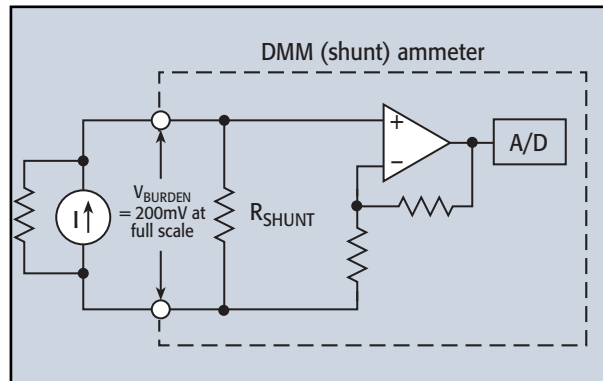
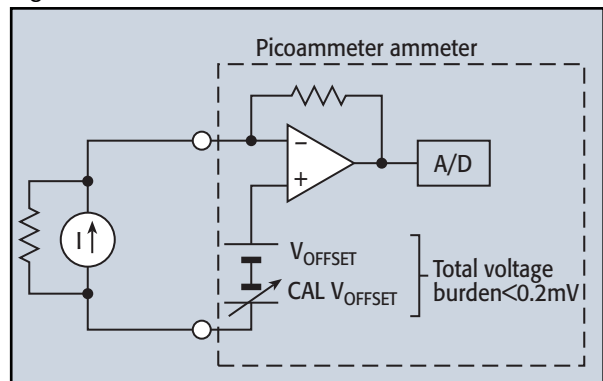

Figure 2



Models 6485/6487— exceptional low current measurement performance



Our latest 5½-digit picoammeters employ the latest current measurement technology, but they're much less expensive than other instruments that perform similar functions, such as optical power meters, competitive picoammeters, or user-designed solutions. With eight ranges and high speed autoranging, the Model 6485 can measure currents from 20fA to 20mA quickly. Its superior sensitivity lets it characterize low current phenomena, while its 20mA range is useful for measuring 4-20mA sensor loops. The Model 6487 adds a built-in 500V source to all the capabilities of the Model 6485, so it's ideal for measuring high resistances or applying a bias voltage to generate currents. The source also makes the Model 6487 a more complete, flexible measurement solution.

Low voltage burden

The feedback picoammeter design of these instruments reduces voltage burden to $<200\mu\text{V}$ on the lower measurement ranges, so they can make current measurements with high accuracy, even in circuits with very low source voltages.

Just like before, only better

With top speeds of 1000 readings per second, these are the fastest picoammeters we've ever made. They offer ten times greater resolution than earlier Keithley picoammeters on every range, as well as an additional 20mA range. A time-stamped data buffer provides minimum, maximum, and standard deviation statistics on up to 2500 stored readings for the Model 6485 or 3000 readings for the Model 6487. Built-in emulation modes simplify upgrading applications originally configured with our older picoammeters.

Flexible interface options

These picoammeters are designed for easy connection to and synchronization with other instruments and sources. For example, each has a built-in Trigger Link interface that combines six independent selectable trigger lines on a single connector for simple, direct control over all instruments in a system. They also include a CE-approved IEEE-488 interface for PC control via the GPIB bus, as well as an RS-232 interface. A digital I/O interface in the Model 6487 simplifies linking it to automated component handling systems.

Low current measurements made easy

A variety of features contribute to these instruments' measurement accuracy. Rear panel BNC inputs on the Model 6485 allow the use of inexpensive, easy-to-use BNC cables. The Model 6485 provides 220V overload protection on all ranges, while the Model 6487 is protected to 500V, so they can withstand abusive overflows. A REL function permits making relative readings with respect to a baseline value; the LOG function displays the logarithm of the absolute value of the measured current. Both instruments can be digitally calibrated using the front panel controls or via the IEEE-488 bus. A scaled voltage analog output simplifies transmitting results to devices like DMMs, data acquisition cards, oscilloscopes, or strip chart recorders. For research on light-sensitive components, such as measuring the dark currents of photodiodes, the front panel display can be switched off to avoid introducing light that would interfere with making accurate measurements.

Resistance measurement flexibility

The Model 6485 can calculate resistance by dividing an externally sourced voltage value by the measured current. The Model 6487's voltage source lets it make direct resistance measurements from 50Ω to $5 \times 10^{14}\Omega$ using the Source Voltage/ Measure Current method. For more accurate measurements of devices with high background current or high noise, the Model 6487 also allows measuring resistance with the Alternating Voltage method, which extends the range to $10^{16}\Omega$.

at an affordable price

Powerful software options

To simplify integrating them into PC-based test systems, both picoammeters come with the ExceLINX™ add-in utility for Microsoft® Excel. Within minutes of installing it on a PC, users can acquire data directly from the instrument, then use Excel's graphics, charting and analysis capabilities to turn that data into useful information with just a few mouse clicks. IVI-style instrument drivers (VISA based) for use with Application Development Environments such as LabVIEW™, LabWindows™/CVI, Visual Basic, C/C++, and TestPoint are also included. Numerous examples and an online help utility let programmers get their applications "Up & Running" quickly.

Condensed Model 6485/6487 specifications

RANGE	5½-DIGIT DEFAULT RESOLUTION	ACCURACY (1YR) ¹ ±(%rdg + offset) 18-28°C, 0-70% RH		TYPICAL RMS NOISE ²		TYPICAL ANALOG RISE TIME (10% to 90%) ³		
						6487 WITH DAMPING ⁴		
		6487		6485	6487	6485	OFF	ON
2 nA	10 fA	0.4% + 400 fA	0.3% + 400 fA	20 fA	20 fA	8 ms	4 ms	80 ms
20 nA	100 fA	0.4% + 1 pA	0.2% + 1 pA	100 fA	100 fA	8 ms	4 ms	80 ms
200 nA	1 pA	0.2% + 10 pA	0.2% + 10 pA	1 pA	1 pA	500 μs	300 μs	1 ms
2 μA	10 pA	0.15% + 100 pA	0.15% + 100 pA	10 pA	1 pA	500 μs	3500 μs	1 ms
20 μA	100 pA	0.1% + 1 nA	0.1% + 1 nA	100 pA	100 pA	500 μs	110 μs	110 μs
200 μA	1 nA	0.1% + 10 nA	0.1% + 10 nA	1 nA	1 nA	500 μs	110 μs	110 μs
2 mA	10 nA	0.1% + 100 nA	0.1% + 100 nA	10 nA	10 nA	500 μs	110 μs	110 μs
20 mA	100 nA	0.1% + 1 μA	0.1% + 1 μA	100 nA	10 nA	500 μs	110 μs	110 μs

INPUT VOLTAGE BURDEN: <200μV on all ranges except <1mV on 20mA range.

LANGUAGE EMULATION: 6485–Keithley Model 485 command emulation via DDC mode; 6487–Keithley Model 486/487 command emulation via DDC mode.

TEMPERATURE COEFFICIENT: 0°-18°C & 28°-50°C For each °C, add 0.1 x (% rdg + offset) to accuracy spec.

ANALOG OUTPUT: Scaled voltage output (inverting 2V full scale on all ranges) 6485–3% ±2mV, 1kΩ impedance, 6487–2.5% ±2mV.

NMRR1: (50 or 60Hz): 60 dB.

MAXIMUM CONTINUOUS INPUT VOLTAGE: 6485–220VDC, 6487–505VDC

¹ At 1 PLC – limited to 60 rdgs/sec under this condition • ² At 6 PLC – limited to 10 rdgs/sec under this condition • ³ Measured at analog output with resistive load >2kΩ.
⁴ Maximum rise time can be up to 25% greater.

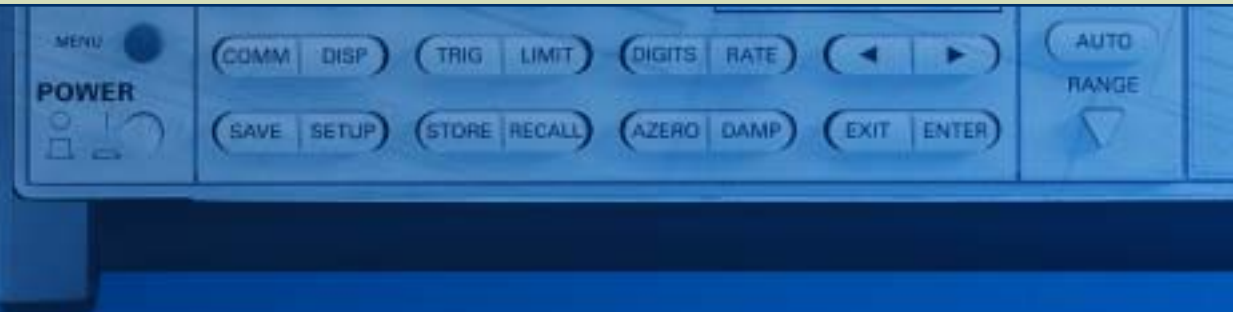



High measurement accuracy

Model 6485 applications

- Materials and components characterization
- Photodiode current measurements
- Dark current (photodiode leakage)
- Fiber alignment
- SEM beam current measurements
- Particle and beam monitoring
- Fluorometer and spectrometer measurements
- Circuit test and analysis
- Teaching labs

Model 6487 applications

- Resistivity and leakage current measurements
- Insulation resistance measurements
- Device I-V characterization
- Photomultiplier current measurements
- Sensor characterization

Measuring picoamps at high speeds demands a special solution



Model 428 Current Amplifier

The **Model 428** is designed to convert small currents into voltages that can be displayed on a scope or waveform analyzer. A feedback circuit design gives the Model 428 both fast rise times and sub-picoamp noise. Rise times from $2\mu\text{s}$ to 300ms can be selected. The amplifier gain can be adjusted in decade steps from 10^3V/A to 10^{11}V/A . Like Keithley's other picoammeters, the Model 428 has zero check and offset functions to enhance the integrity of signals with voltage offsets. Up to 5mA of current can be suppressed, which can be useful for nulling out a residual or offset current present at the Model 428's input. A choice of three display intensities—bright, dim, and off—makes it suitable for use in light-sensitive environments.

Model 428 applications include:

- Biochemistry measurements, such as ion channel currents through cell walls and membranes
- Beam position monitoring, such as in electron storage rings and synchrotrons
- Surface science studies
 - Amplifier for a Scanning Electron Microscope (SEM)
 - Observing secondary electron emission, as in X-ray and beam line currents
- Laser and light measurements
 - Amplifier for use with PMTs and photodiodes
 - Analysis of fast photoconductive materials
 - IR detector amplifier
- Transient phenomena
 - Current DLTS studies
 - Breakdown in devices and dielectrics
- Front-end amplifier/converter for oscilloscopes or waveform digitizers
- Fiber alignment

Common picoammeter applications

Transistor leakage current testing

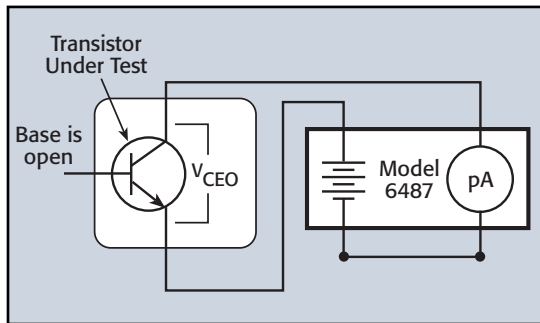

Testing bipolar transistors typically involves two leakage current measurements: I_{CEO} (collector-emitter with base open) and I_{CBO} (collector-base with emitter open). To measure the leakage current, a voltage potential is placed across two terminals with the third terminal open, and the resulting current is measured. The Model 6487 is ideal for this application because of its integrated voltage source. Its low voltage burden allows measuring small leakage currents without degrading the measurement. The instrument's internal memory can store results as the test runs, then the data can be recalled and plotted.

Monitoring and control of focused ion beam currents

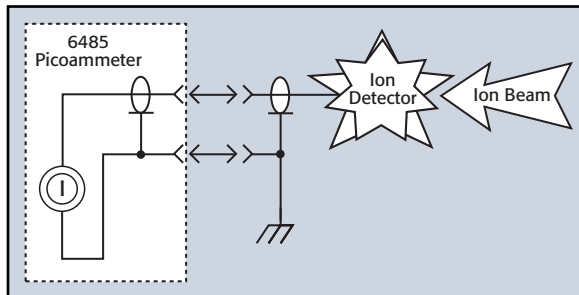

In semiconductor fabrication, focused ion beam systems are often used for nanometer-scale imaging, micromachining, and mapping. Careful monitoring of the magnitude of the beam current with an ion detector is critical. The ion detector generates a secondary current that's proportional to the current of the primary ion beam. When this secondary current is measured, it can be used to control the intensity of the primary beam. However, this secondary current is very low, often just a few picoamps, so the instrumentation measuring it must provide high measurement accuracy and repeatability, as well as sub-picoamp resolution. The Model 6485's wide measurement range and 5½-digit resolution make it ideal for this application. Signal connections to the Model 6485 are made through the instrument's BNC connector.

Wafer-level photodiode testing

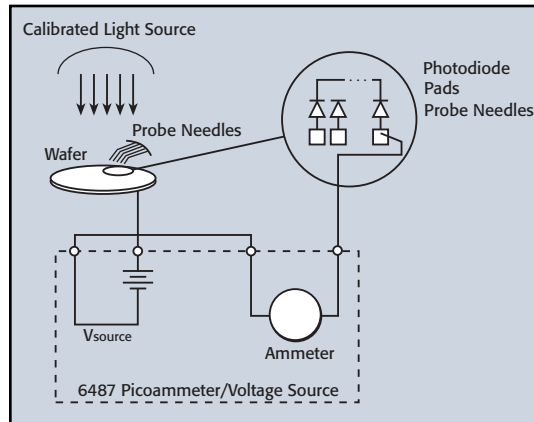

The Model 6487 Picoammeter can be paired with a calibrated light source and a probing fixture to create a cost-effective photodiode test system. Multiple Model 6487s can be connected to the DUT's probe pads to provide photocurrent readings or, with the addition of a switch matrix, one or more picoammeters can take current measurements from multiple pads. The Trigger Link interface available on the Model 6487 simplifies synchronizing these instruments, providing control over photocurrent measurement from more than one picoammeter. In the first step of the measurement process, performed in total darkness, the Model 6487 produces a voltage sweep and measures the resulting dark current. In the second step, a fixed voltage bias is applied and the resulting photocurrent is measured while the light level is increased in calibrated steps. The same basic test configuration can be used for testing positive intrinsic negative (PIN) and avalanche photodiodes (APDs).

High resistance measurements

The Model 6487's Picoammeter/Voltage Source can be used to measure high resistances ($>1G\Omega$) in applications such as insulation resistance testing. The voltage source is placed in series with the unknown resistance and the picoammeter. The voltage drop across the picoammeter is negligible, so essentially all the voltage appears across the unknown resistance. The resulting current is measured by the picoammeter and the resistance is calculated using Ohm's Law ($R=V/I$). To prevent generated current due to electrostatic interference, the unknown resistance is housed in a shielded test fixture. For resistance measurements greater than $1T\Omega$, the 6487 employs the alternating voltage method.

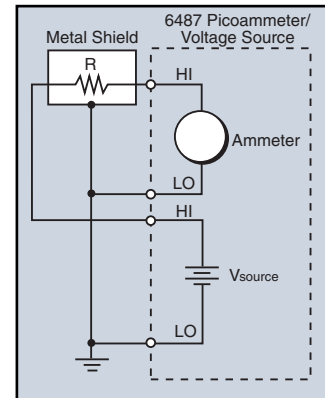

All the support you need

Informative reference materials

Visit our web site, www.keithley.com, to access our reference library, including:

Low Level Measurements

This informative handbook describes theoretical and practical considerations involved in the measurement of low DC currents, high resistances, low DC voltages, and low resistances.



Application Notes

These helpful notes include practical, real-world answers to many application questions related to low level measurements.

Lab Exercises

Keithley's suite of lab exercises is designed to help students learn about making electrical and physical measurements through hands-on experience. Many lab exercises are available for free downloading from our website. For example:

- Energy Gap in a Semiconductor
- Digital Multimeter and Oscilloscope
- Linear Op Amp Circuits
- Step Response of Passive Circuits
- The Electric Field
- Field Effect Transistors
- Non-Linear Op Amp Circuits
- Frequency Domain Analysis of Signals

Service you can depend on

When you need help, contact us at www.keithley.com or call us at 1-888-KEITHLEY (534-8453). Whatever your application, Keithley's application engineers are ready to help you meet its challenges, before and after the sale. You can rely on us to suggest the most effective system configurations and to provide prompt, reliable applications support once your system is set up.

The next time you're faced with a challenging application, give us a call. We'll offer you a cost-effective solution that will help you improve your product quality, throughput, and yield.

A greater measure of confidence

With more than a half-century of expertise in making demanding low level measurements, Keithley offers its customers a greater measure of testing confidence on the production floor, in the QA lab, and in R&D. For more information on how Keithley test solutions can help you keep pace with changing technologies, call your local Keithley sales engineer or visit our website.

Specifications are subject to change without notice.

All Keithley trademarks and trade names are the property of Keithley Instruments, Inc.

All other trademarks and trade names are the property of their respective companies.

KEITHLEY

A G R E A T E R M E A S U R E O F C O N F I D E N C E

Keithley Instruments, Inc.

Corporate Headquarters • 28775 Aurora Road • Cleveland, Ohio 44139 • 440-248-0400 • Fax: 440-248-6168 • 1-888-KEITHLEY (534-8453) • www.keithley.com

Belgium: Sint-Pieters-Leeuw • 02-363 00 40 • Fax: 02-363 00 64 • www.keithley.nl

China: Beijing • 8610-82251886 • Fax: 8610-82251892 • www.keithley.com.cn

Finland: Helsinki • 09-5306-6560 • Fax: 09-5306-6565 • www.keithley.com

France: Palaiseau Cédex • 01-64 53 20 20 • Fax: 01-60 11 77 26 • www.keithley.fr

Germany: Germering • 089/84 93 07-40 • Fax: 089/84 93 07-34 • www.keithley.de

Great Britain: Theale • 0118 929 7500 • Fax: 0118 929 7519 • www.keithley.co.uk

India: Bangalore • 080 212 8027 • Fax: 080 212 8005 • www.keithley.com

Italy: Milano • 02-48 39 16 01 • Fax: 02-48 30 22 74 • www.keithley.it

Japan: Tokyo • 81-3-5733-7555 • Fax: 81-3-5733-7556 • www.keithley.jp

Korea: Seoul • 82-2-574-7778 • Fax: 82-2-574-7838 • www.keithley.com

Netherlands: Gorinchem • 0183-635333 • Fax: 0183-630821 • www.keithley.nl

Singapore: Singapore • 65-6747-9077 • Fax: 65-6747-2991 • www.keithley.com

Sweden: Solna • 08-509 04 600 • Fax: 08-655 26 10 • www.keithley.com

Taiwan: Hsinchu • 886-3-572-9077 • Fax: 886-3-572-9031 • www.keithley.com.tw