

Agilent Technologies 81100 Family of Pulse Pattern Generators

Technical Specifications



Agilent 8110A

Signals for testing digital designs and components

The Agilent 81101A, 81104A, 81110A and 81130A generate all the standard pulses and digital patterns needed to test current logic technologies (CMOS, TTL, LVDS, ECL, etc.).

With the optional second channel on all of the models from 80 MHz to 660 MHz, multi-level and multi-timing signals can be obtained using the internal channel addition feature.

- Variable pulse parameters in pattern mode as well as in pulse mode (not on the 81130A)
- Synchronously triggerable
- Simulation of reflections/distortions (81104A, 81110A)
- Three/four-level codes (81104A, 81110A)

Flexible pulses or patterns for digital designs

Key Features

- Pattern mode on all models from 80 MHz to 660 MHz, including pseudo-random binary sequence.
- The outputs of dual-channel instruments can be added (analog or EXOR, depending on model).
- User-retrofitable channels for most models
- Upward compatibility
- Individual solutions for frequencies up to 50, 80, 165, 330, 400 and 660 MHz
- 100% form/fit compatibility



Glitch-free timing changes

Timing values can now be swept without the danger of misleading pulses or dropouts that could cause measurement errors. (Applies to continuous mode, values < 100 ms, consecutive values between 0.5 and twice the previous value on the 81101A, 81104A, 81110A)

Reliable measurements

All models provide clean, accurate pulses with excellent repeatability, thus contributing to measurement integrity.

The Agilent 81110A features self-calibration for more accuracy. It also offers a choice of output modules. The Agilent 81111A 165 MHz 10 V module with variable transitions. Along with the Agilent 81112A 330 MHz 3.8 V module,

which has differential outputs and two selectable transition times. The Agilent 81130A offers a choice of output modules: the Agilent 81131A 400 MHz, 3.8 V module and the Agilent 81132A 660 MHz, 2.5 V module which has complementary outputs.

Easy-to-use

Features such as the clear graphical display, autoset, help, store/recall, preset TTL/ECL levels, selectable units (such as current/voltage, width/duty-cycle), and load compensation ensure a high level of convenience.

Stimulate the device's environment

Today's devices can require very complex stimuli. To meet this, the Agilent 81130A can sequence and loop its memory for very deep patterns. RZ (return-to-zero), NRZ (non-return-to-zero) and R1 (return-to-one) formats are available. Digital channel addition allows the generation of signals with two different pulse widths and delays or of data rates up to 1.32 Gbit/s in one single channel.

Frequency range

The Agilent 81130A is designed and recommended for an operation in the frequency range of 170 kHz to 400/660 MHz. However it can be operated in the extended range down to 1 kHz.

Agilent 81100 - Family of Pulse Pattern Generators

Mainframes	81101A	81104A	81110A3		81130A	
Channel Model	n.a.	81105A	81111A	81112A	81131A	81132A
Nr. of channels	1 Single ended	1 or 2 Single ended	1 or 2		1 or 2	
			Single ended	differential	Single ended	differential
Frequency range	1 mHz - 50 MHz	1 mHz - 80 MHz	1 mHz - 165 MHz	1 mHz - 330 MHz	1 kHz - 400 MHz	1 kHz - 660 MHz
Period range	20 ns to 999.5 s	12.5 ns to 999.5 s	6.06 ns to 999.5 s	1.515 ns to 999.5	2.5 ns to 1 ms	1.5 ns to 1 ms
Variable delay range	0.00 s - 999.5 s	0.00 ns - 999.5 s	0.00 ns - 999.5 s		0.00 ns to 3.00 μ s	
Period RMS - jitter	0.01% + 15 ps ²	0.01% + 15 ps ²	0.01% + 15 ps ²		0.01% + 15 ps ²	
Width range	10 ns to 999.5 s	6.25 ns to 999.5 s	3.03 ns to 999.5 s	1.515 ns to 999.5 s	1.25 ns to (period-1.25 ns)	70 ps to (period-750 ps)
Amplitude range	100 mV to 20.0 V ¹	100 mV to 20.0 V ¹	100 mV to 20.0 V ¹	100 mV to 3.8 V	100 mV to 3.8 V	100 mV to 2.5 V
Transition time range (10/90)	5.00 ns to 200 ms	3.00 ns to 200 ms	2.00 ns to 200 ms	800 ps or 1.6 ns selectable	800 ps or 1.6 ns selectable	500 ps typ. fixed
Dropout- and glitch- free timing change	yes	yes	yes		No	
Source Impedance	50 Ω or 1 k Ω	50 Ω or 1 k Ω	50 Ω or 11 k Ω	50 Ω	50 Ω	

- (1) Depends on selected impedance (all other values for 50 Ω source impedance into 50 Ω load)
- (2) 0.001% +15 ps with internal PLL as clock source
- (3) Also available as VXI Pulse Pattern Generators E8311A and E8312A

81101A Specifications

Timing Characteristics

Measured at 50% amplitude at fastest transitions in continuous mode and 50 Ω source impedance.

Mainframe	Agilent 81101A
Frequency range	1mHz to 50MHz
Timing resolution	3.5 digits, 5ps best case
Period RMS jitter	
With PLL	0.001% + 15 ps
With VCO	0.01% + 15 ps
Period range	20ns to 999.5 s
Accuracy with PLL /VCO	± 0.01% (±5%) (similar to RMS Jitter)
Width range	10.0 ns to (period - 10.0 ns)
Accuracy	±5% ±250 ps ⁽¹⁾
RMS Jitter	0.01% + 15 ps
Additional variable delay range	0 ns to (period -20 ns)
Accuracy ⁽²⁾	±5% ±1 ns
RMS Jitter	0.01% + 15 ps
Double pulse delay range	(width + 10.0 ns) to (period- width - 10.0 ns)
Accuracy	±5% ± 500 ps
Transition time range (10/90)	5 ns to 200 ms variable
Accuracy	±10% ±200 ps
Linearity	3% typ. for transitions > 100 ns

Note:

(1) Changing of amplitude may add 0.5 ns.

(2) Width accuracy specification is valid up to 5.5 Vpp amplitude. Above this amplitude, the width will typically increase up to 300ps

Burst Count: 2 to 65536 (single or double pulses).

Delay: Delay, phase or % of period.

Double pulse delay: Double pulse and delay are mutually exclusive.

Duty cycle: Set between 0.1% and 95% (subject to width limits. 99.9% with overprogramming).

Transition times: These can be Entered as leading/ trailing edge or % of width. Leading and trailing edges are independent within one of the following overlapping segments (1:20 ratio):

5 ns - 20 ns, 10 ns - 200 ns, 100 ns - 2 μs, 1μs - 20 μs, 10 μs - 200 μs, 100 μs - 2 ms, 1 ms - 20 ms, 10 ms - 200 ms.

Transition times: These can be entered as leading/ trailing edge or % of width. Leading and trailing edges are independent within one of the following overlapping segments (1:20 ratio):

5 ns - 20 ns, 10 ns - 200 ns, 100 ns - 2 μs, 1μs - 20 μs, 10 μs - 200 μs, 100 μs - 2 ms, 1 ms - 20 ms, 10 ms - 200 ms.

Repeatability: Is typically four times better than accuracy

Output timing fidelity: Period, delay and width are continuously variable without any output glitches or dropouts.

Level/Pulse Performance Characteristics

Level specifications are valid after a 30 ns typical settling time.

Agilent 81101A		
Amplitude	50 Ω into 50 Ω	100 mV _{pp} to 10.0 V _{pp}
	1 kΩ into 50 Ω	200 mV _{pp} to 20.0 V _{pp}
Level window	50 Ω into 50 Ω	-10.0 V to +10.0 V
	1 kΩ into 50 Ω	-20.0 V to +20.0 V
Accuracy	50 Ω into 50 Ω	± (3% + 75 mV)
	1 kΩ into 50 Ω	± (3% + 150 mV) ¹⁾
Resolution	50 Ω into 50 Ω	10 mV
	1 kΩ into 50 Ω	20 mV
Output connectors	BNC single-ended	
Source Impedance	Selectable 50 Ω or 1 kΩ	
Accuracy	Typ. ± 1%	
Max. external voltage	± 24 V	
Short circuit current	± 400 mA max.	
Base line noise	10 mV RMS typ.	
Overshoot/preshoot/ringing	± 5% of amplitude ± 20 mV	

Note: (1) In ±19 V level window

Trigger Modes

Continuous: Continuous pulses, double pulses or bursts (single or double pulses).

External triggered: Each active input transition (rising, falling or both) generates a single or double pulse or burst.

External gated: The active input level (high or low) enables pulses, double pulses or bursts. The last single / double pulse or burst is always completed.

External width: The pulse shape can be recovered whilst the period and width of an external input signal are maintained. Levels and transitions can be set.

Typical delay times Agilent 81101A

Instrument mode	From	To	Typ. value
External width	Ext. Input	Strobe/Trigger out	8.5 ns
		Output 1/Output 2	22.5 ns
All other modes	Ext. Input/Clk input	Strobe/Trigger out	12.0 ns
		Output 1/Output 2	29 ns
	Strobe/Trigger out	Output 1/Output 2	17 ns

Ext. input: Used for trigger, gate or external width.

Level parameters: Can be entered as voltage or current, as high and low level, or as offset and amplitude.

Load compensation: The actual load value can be entered (for loads ≠50 Ω) to display actual output values.

On/off: Relays connect/disconnect output (HiZ).

Normal/complement: Selectable.

Limit: Programmable high and low levels can be limited to protect the device-under-test.

Input impedance: 50 Ω/10 kΩ selectable.

Threshold: -10 V to +10 V.

Max. input voltage: ±15 V_{pp}.

Sensitivity: 300 mV_{pp} typical.

Input transitions: <100 ns.

Frequency: Dc to 50 MHz .

Minimum pulsewidth: 10 ns

Strobe output and trigger output

Trigger format: One pulse per period with 50% duty cycle typical.

External mode: 9 ns typ.

Level: TTL or ECL selectable.

Output impedance: 50 Ω typical.

Max. external voltage: -2 V/+7 V.
Transition times: 1.0 ns typical for TTL, 600 ps typical for ECL.

81104A and 81110A Specifications

Timing Characteristics

Measured at 50% amplitude at fastest transitions in continuous mode and 50 Ω source impedance.

Mainframe Output module	Agilent 81104A Agilent 81105A	Agilent 81110A Agilent 81111A	Agilent 81110A Agilent 81112A
Frequency range From 1 K Ω	1 mHz to 80 MHz Up to 50 MHz typ.	1 mHz to 165 MHz Up to 60 MHz typ.	1 mHz to 330 MHz N/A
Timing Resolution	3.5 digits, 5 ps best case		
Period Range	12.5 ns to 999.5 s		
Period RMS jitter With PLL With VCO	0.001% + 15 ps 0.01% + 15 ps		
Accuracy with PLL VCO	0.001% +15 ps $\pm 0.01\%$ ($\pm 5\%$)	$\pm 0.01\%$ ($\pm 0.5\%$ typ. After self-cal., $\pm 3\%$ without self-cal.)	
Width range	6.25 ns to (period - 6.25 ns)	3.03 ns to (period - 3.03 ns)	1.515 ns to (period - 1.515 ns)
Accuracy	$\pm 5\% \pm 250$ ps		
Jitter (RMS)	0.01% + 15 ps		
Add. Variable delay range Accuracy	0 ns to (period -12.5) $\pm 5\% \pm 0.5$ ns	0 ns to (period -3.03 ns) $\pm 0.5\% \pm 0.5$ ns typ. $\pm 3\% \pm 0.5$ ns after self-cal.	
Jitter (RMS)	0.01% +15 ps		
Double pulse delay range Min period	12.5 ns to (period - width - 6.25 ns) 25 ns (40 MHz) typ.	6.06 ns to (period - width - 3.03 ns) 12.2 ns (82 MHz) typ.	3.03 ns to (period - width - 1.5) 6.06 ns (165 MHz) typ. $\pm 0.5\% \pm 150$ ps typ. $\pm 3\%$ ± 150 ps after self-cal.
Accuracy	$\pm 5\% \pm 250$ ps		
Transition time range (10/90) Minimum (with overprogramming)	3 ns to 200 ms variable ≤ 3 ns	2 ns to 200 ms variable ≤ 2 ns/1.4 ns typ. For ELC levels (20/80) 5 ns typ. For 1 K Ω source impeded	0.8 ns or 1.6 ns selectable ≤ 600 ps for $V_{pp} \leq 1$ V 450 ps typ. For ELC levels (20/80) ≤ 900 ps for $V_{pp} > 1$ V
Accuracy	$\pm 10\% \pm 200$ ps		
Linearity	3% typ. For transitions < 100 ns		N/A

Burst Count: 2 to 65536 (single or double pulses).

Delay: delay, phase or % of period.

Double pulse and delay: mutually exclusive.

Duty cycle: set between 0.1% and 95% (subject to width limits. 99.9% with overprogramming).

Repeatability: is typ. four times better than accuracy.

Transition times: leading/ trailing edge or % of width. Leading and trailing edges are independent Agilent 81111A/Agilent 81105A) within one of the following overlapping segments (1:20 ratio): 2 ns (3 ns) - 20 ns, 10 ns - 200 ns, 100 ns - 2 ms, 1 μ s - 20 μ s, 10 μ s - 200 μ s, 100 μ s - 2 ms, 1 ms - 20 ms, 10 ms - 200 ms.

Output timing fidelity: period, delay and width are continuously variable without any output glitches or dropouts.

Overprogramming: all parameters of the Agilent 81110A, except transitions, can be set to whatever the 330 MHz timing system will allow. This applies also when the Agilent 81111A (165 MHz) output module is used.

Level/Pulse Performance Characteristics

Level specifications are valid after a 5 ns (Agilent 81112A) or 30 ns (Agilent 81111A/Agilent 81105A) typical settling time.

Mainframe	Agilent 81101A Agilent 81105A	Agilent 81110A Agilent 81111A	Agilent 81110A Agilent 81112A
Amplitude	50 Ω into 50 Ω	100 mV _{pp} to 10.0 V _{pp}	
Level window	50 Ω into 50 Ω 1 kΩ into 50 Ω	-10.0 V to +10.0 V -20.0 V to +20.0 V	
Accuracy	50 Ω into 50 Ω 1 kΩ into 50 Ω	± (3% + 75 mV) ± (3% + 150 mV) ⁽¹⁾	± (1% + 50 mV) ± (1% + 100 mV) ⁽¹⁾
Resolution	50 Ω into 50 Ω 1 kΩ into 50 Ω	10 mV 20 mV	
Output connectors	BNC single-ended		BNC differential
Source Impedance	Selectable 50 Ω or 1 kΩ		50 Ω only
Accuracy	Typ. ± 1%		
Max. external voltage	± 24 V		-2.2 V to +5.5 V
Short circuit current	±400 mA max. (doubles for channel addition)		-84 mA to + 152 mA
Dynamic Crosstalk	< 0.1% typ.		
Base line noise	10 mV RMS typ. 4 mV RMS typ.		
Overshoot/preshoot/ringing	± 5% of amplitude ± 20 mV		± 5% of amplitude ± 50 mV

Note:

(1) in ± 19 V level window

Level parameters: voltage or current, high or low level, offset or amplitude.

On/off: relays connect/ disconnect output (HiZ)

Load compensation: the actual load value can be entered (for loads ≠ 50 Ω) to display actual output values.

(Applies to the Agilent 81105A and Agilent 81111A only).

Normal/complement: selectable.

Limit: programmable high and low levels can be limited to protect the device-under-test.

Channel Addition (with Agilent 81105A or Agilent 81111A output channels)

If the instrument is equipped with 2 output modules, channel 2 can be added to channel 1 internally. In this case the second output is disabled. The additional fixed delay on the second channel is typ. 2.5 ns. The following parameters differ from the above specifications if two output modules (Agilent 81105A/Agilent 81111A) are added.

Mainframe	Agilent 81104A with two Agilent 81105A output modules	Agilent 81110A with two Agilent 81111A output modules
Amplitude	50 Ω into 50 Ω 1 kΩ into 50 Ω	100 mV _{pp} to 20.0 V _{pp} 200 mV _{pp} to 20.0 V _{pp}
Source Impedance	Selectable from 50 Ω or 1 kΩ	
Level window	50 Ω into 50 Ω 1 kΩ into 50 Ω	-20.0 V to +20.0 V -20.0 V to +20.0 V
Max. frequency	50 Ω channel 1 kΩ channel	60 MHz typ. 15 MHz typ.
Min. transitions	50 Ω channel 1 kΩ channel	2 ns typ. (channel one) 5 ns typ. (channel two) 20 ns typ. both channels

Pattern Mode

Pattern length: 16 kbit/channel and strobe output.

Output format: RZ (return to zero), NRZ (non-return to zero), DNRZ (delayed non-return to zero).

Random pattern:
PRBS $2^{(n-1)}$ n = 7,8,...,14.

Trigger Modes

Continuous: continuous pulses, double pulses, bursts (single or double pulses) or patterns.

External triggered: each active input transition (rising, falling or both) generates a single or double pulse, burst or pattern.

External gated: the active input level (high or low) enables pulses, double pulses, bursts or patterns. The last single/double pulse, burst or pattern is always completed.

External width: the pulse shape can be recovered. Period and width of an external input signal is maintained. Delay, levels and transitions can be set.

Manual: simulates an external input signal.

Internal triggered: internal PLL replaces an external trigger source. Pulses, double pulses, bursts or patterns can be set.

Inputs and Outputs

Clock input/PLL reference and external input

PLL reference: (BNC connector at rear panel). The internal PLL is locked to an external 5 MHz or 10 MHz reference frequency.

Clock input: (BNC connector at rear panel). The output period is determined by the signal at CLK input.

Ext. input: used for trigger, gate or external width.

Input impedance:
50 Ω /10 k Ω selectable.

Threshold: - 10 V to + 10 V.

Max. input voltage: ± 15 V_{pp}.

Sensitivity: ≤ 300 mV_{pp} typical.

Transitions: < 100 ns.

Frequency: dc to max. frequency of output module.

Min. pulsewidth: 1.5 ns (as width of output module in external width mode).

Strobe output and trigger output

Strobe output: user-defined, 16 kbit pattern (NRZ) when in pattern mode.

Trigger format: one pulse per period with 50% duty cycle typical. External mode: 1.5 ns typ. for Agilent 81110A. 5.9 ns typ. for Agilent 81104A.

Level: TTL or ECL selectable.

Output impedance: 50 Ω typical.

Max. external voltage: - 2 V/+7 V.

Transition times: 1.0 ns typical for TTL, 600 ps typical for ECL.

Typical delay (Agilent 81110A with Agilent 81111A output module) ^[1]

Instrument mode	From	To	Typ. value
External width	Ext. Input	Strobe/Trigger out	8.5 ns
		Output 1/Output 2	19.5 ns
All other modes	Ext. Input/Clk Input	Strobe/Trigger out	12.0 ns
		Output 1/Output 2	26.0 ns
		Strobe/Trigger out	14.0 ns

Note:

[1] Subtract 4 ns from the typ. delay value when referring to OUTPUT1/2 for the Agilent 81112A output module and add 1 ns when referring to OUTPUT1/2 for the Agilent 81104A with the Agilent 81105A output module.

81130A Specifications

Timing Characteristics

Measured at 50% amplitude at fastest transitions in continuous mode and 50 Ω source impedance. The Agilent 81130A is designed and recommended for an operation in the frequency range of 170 kHz to 400/660 MHz. However it can be operated in the extended range down to 1 kHz. Changes in specifications below 170 kHz are marked.

Mainframe Output module	Agilent 81130A Agilent 81131A	Agilent 81130A Agilent 81132A
Frequency range	170 kHz (1 kHz) to 400 MHz	170 kHz (1 kHz) to 660 MHz
Frequency resolution	4 digits, (2 ps best case)	
Period Range	2.5 ns to 5.9 μ s 1.50 ns to 5.9 μ s (f < 170 kHz: 2.5 ns to 1 ms)	(f < 170 kHz: 1.5 ns to 1.0 ms)
Accuracy	\pm 100 ppm	
RMS jitter (int ref, int clk)	0.001% + 15 ps	
Width range	1.25 ns to period - 1.25 ns)	1.25 ns to period - 1.25 ns)
Width resolution	4 digits (2 ps best case) (f < 170 kHz: 0.05% of period)	
Width accuracy	\pm (100 ppm + 200 ps) (f < 170 kHz: 0.06% of period)	
Width jitter	0.0001% + 15 ps	
Add, variable delay range	0 to 3.00 μ s independent of period (> 3 μ s: one to 1 period)	
Delay resolution	4 digits (2 ps best case) (f < 170 kHz: \pm 0.05% of period)	
Delay accuracy	\pm (0.01% + 100 ps) relative to zero delay (f < 170 kHz: \pm 0.035% of period)	
Delay jitter	0.001% + 15 ps	
Fixed delay (clk in to out) (ext. in to out)	53 ns 54 ns + 0 to 1 period (1)	
Transition time range (10/90)	800 ps or 1600 ps	fixed
Minimum transition (10/90)	\leq 600 ps for $V_{pp} \leq 1$ V \leq 900 ps for $V_{pp} \leq 1$ V	500 ps typ.
At ELC levels (20/80)	450 ps typ.	< 350 ps (200 ps typ.)
Deskew range	\pm 25 ns	

Note:

(1) The uncertainty of 1 period can be eliminated if an external clock and the following setup and hold times are upheld.
setup time: 0.3 ns to 4.3 ns; hold time: -2.8 ns to 4.0 ns.

Burst Count: 2 to 65504.

Delay: delay, phase or % of period.

Duty cycle: set between 0.1% and 99,9% (subject to width limits).

Repeatability: is typ. four times better than accuracy.

Level/Pulse Performance Characteristics

Level specifications are valid after a 30 ns typical settling time (50 Ω into 50 Ω terminated to ground).

Mainframe	81130A	81130A
Output module	81131A (400 MHz)	81132 A (660 MHz)
Amplitude	0.10 V _{pp} to 3.80 V _{pp}	0.10 V _{pp} to 2.50 V _{pp}
Level Window	-2.00 V to +3.80 V	-2.00 V to +3.00 V
Accuracy	± (5% +150 mV)	
Resolution	3 digits (10 mV best case)	
Output Impedance	50 Ω ± 1%typ.	50 Ω ±5%typ.
Max. external voltage	- 2.2 to +5.5V	-2.0 to +4.0 V
Short circuit current	-80 mA to +152 mA.	-80 mA to +120 mA
Baseline noise	4 mV RMS typ.	8 mV RMS typ.
Overshoot/preshoot/ringing	±(5% + 50 mV) of amplitude typ.	±(5% + 100 mV) of amplitude typ.

Level parameters: Voltage or current, high and low level, or offset and amplitude.

Pattern and Sequencing

Pattern length: 65504 bit/channel. If PRBS is used: (65503-RBLength)

Pattern formats: NRZ (non-return-to-zero), DNRZ (delayed non-return-to-zero), RZ (return-to-zero) and R1 (return-to-one) can be selected (see figure 1)

On/off: Relays connect/disconnect output (HiZ).

Sequencing: A sequence is a succession of segments. One outer loop running once or continuous, and one nested loop can be applied. The nested loop can be set from 1 to 2²⁰ repetitions.

Segment: The memory can be divided into maximal 4 segments.

Segment length resolution: This is the resolution for which the segment can be set dependent on the maximum data rate. (see table 1)

Limit: Programmable high and low levels can be limited to protect the device-under-test.

Segment types: Pattern, PRBS, high and low segments ("0" or "1" levels segments selectable). Note: If one channel is set to PRBS the other channel can only be high or low segments, or PRBS type.

Random Pattern: PRBS 2ⁿ⁻¹, n = 7,8,...,15 (CCITT 0.151)

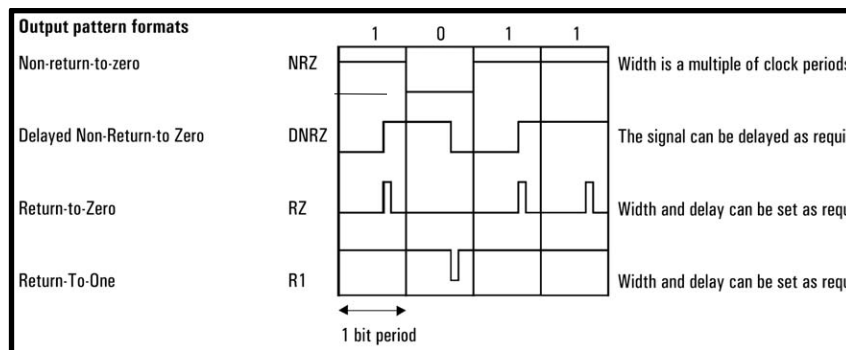

Figure 1: Pattern Formats

Required Segment length resolution [1]	Maximum data rate, Mbit/s
1 bit	41.67
2 bits	83.88
4 bits	166.67
8 bits	333.33
16 bits	660

Table 1 . Segment length resolution trade-offs

[1] The minimum length in the first segment of a nested loop is two times that of the segment length resolution.

Digital Channel Addition

Channel 1 can be logically combined with channel 2 (XOR) as shown in Figure 2. The source impedance remains 50 Ω. Output 2 is still available in this case.

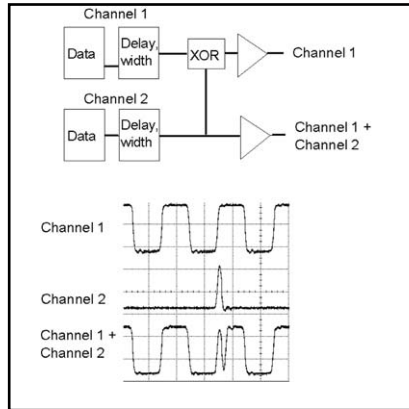

Figure 2: Channel addition

Trigger Modes

Continuous: Continuous pulses, bursts or patterns.

External started: Each active input transition (rising, falling edge) generates pulses, bursts or patterns.

External gated: The active input level (high or low) enables pulses, bursts or patterns. On an external gate signal the output is immediately stopped, that means the last cycle will not be completed.

Manual: Simulates an external input signal with push of a front panel button.

Inputs and Outputs

Clock input/PLL reference and external input

Connectors: SMA (f) 3.5 mm

Input impedance: 50 Ω

Termination voltage: -2.10 V to 3.30 V

Input sensitivity: < 400 mV typ.

Max. Input Voltage: -3 V to + 6 V

Input transitions: < 20 ns

Only valid for clock input/PLL reference One input is used for clock input or for the PLL reference alternatively.

Reference: The internal PLL is locked to the 1,2,5 or 10 MHz.

External clock: The output period is determined by the signal at clock input.

Clock Input frequency: 170 kHz to 660 MHz (at 50% ±10% duty cycle)

Delay from input trigger output: 21ns.

Delay from input to output: 53ns

Threshold: ac coupled

Only valid for external input

External input: Used for external started or gated

Input frequency: DC to 330MHz

Delay from external input to trigger output: 22ns + 0 to 1 period

Delay from external input to output: 54 ns + 0 to 1 period

Threshold: -1.4 V to +3.7 V

Trigger output

Trigger format: One pulse per period with 50% duty cycle typical. In pattern mode the trigger pulse can be set to mark the start of any segment.

Output impedance: 50 Ω typical.

Level: TTL/ETTL (for frequency < 180 MHz), 1 V to GND, ECL 50 Ω to GND/-2 V, PECL 50 Ω to + 3 V.

Max. external voltage: -2 V/+3 V.

Transition times: 1.0 ns typical for TTL, 600 ps typical for ECL.

Delay from external input to trigger output: 32 ns typical

Programming times: (measured at display off.)

ASCII Command	Typical execution time
Width, delay, transition times	40 ms to 70 ms
Period within one range ^[1]	100 ms to 260 ms
Period between different ranges ^[1] :	
In pulse/burst mode	140 ms to 300 ms
in pattern mode	100 ms to 5.05 s
Levels	43 ms
Trigger modes	< 75 ms
Input parameters	28 ms
Save setting	200 ms
Recall setting:	
a) in pulse/burst mode	515 ms to 800 ms
b) in pattern mode with data and PRBS (depends on setting)	1.15 s to 5.5 s
65504 bit pattern transfer	1.25 s
Pattern and sequencing (depends on setting)	190 ms to 5.1 s

[1] Range depends on segment length resolution, see table 1

Common Specifications

User Interface

Overprogramming: all parameters can be overprogrammed (exceeding specifications) to fully exploit the hardware limits.

Setting check: warning messages indicate potentially conflicting parameters due to inaccuracy. Error messages indicate conflicting parameters.

Help key: displays a context-sensitive message.

Autoset key: resolves all timing conflicts.

Non-volatile memory: current setting is saved on power-down. Up to nine user settings and one fixed default setting can be stored in the instrument.

Memory card: 99 settings can be stored on a 1 MB PCMCIA card (MS-DOS®).

Remote Control

Operates according to IEEE standard 488.2, 1987 and SCPI 1992.0.

Function Code: SH1, AH1, T6, L4, SR1, RL1, PP0, DC1, DT1, C0.

ASCII command	Typ. exec. time
One parameter or mode	30 ms typ.
Recall setting	250 ms typ.
16 k pattern transfer	600 ms typ.

Programming times: All checks and display off.

Specifications

Specifications describe the instrument's warranted performance. Non-warranted values are described as typical. All specifications apply after a 30 minute warm-up phase with 50 Ω source/load resistance. All specifications are valid from 0°C to 55°C ambient temperature.

General

Operating temperature: 0°C to +55°C.

Storage temperature: -40°C to +70°C.

Humidity: 95% r.h. up to 40°C ambient temperature.

EMC: conforms to EN50082-1, EN 55011, Class A.

Noise emission: 5.7 bel typical.

Battery: Lithium CR2477-N.

Safety: IEC1010, CSA1010.

Power requirements:
100-240 Vac, \pm 10%, 50-60 Hz;
100-120 Vac, \pm 10%, 400 Hz.

Power consumption:
300 VA max.

Max. dimensions (H * W * D):
89 mm * 426 mm * 521 mm.

Weight: 9.2 kg net, 13.8 kg shipping.

Recalibration period:
Three years recommended.

Complementary Products Pulse Pattern Generator and Oscilloscopes (Real Time or Sampling)

54655A
54854A
54852/3A
D/MSO6100, 54832/33x
D/MSO6050, 54830/31x
D/MSO6030
54622/4x

Inputs and Outputs

Clock input/PLL reference and external input

Connectors: SMA (f) 3.5 mm

Input impedance: 50 Ω

Termination voltage: -2.10 V to 3.30 V

Input sensitivity: < 400 mV typ.
Max. Input Voltage: -3 V to + 6 V

Input transitions: < 20 ns

Only valid for clock input/PLL reference

One input is used for clock input or for the PLL reference alternatively.

Reference: The internal PLL is locked to the 1,2,5 or 10 MHz .

External clock: The output period is determined by the signal at clock input.

Clock Input frequency: 170 kHz to 660 MHz (at 50% \pm 10% duty cycle)

Delay from input trigger output: 21ns.

Delay from input to output:
53ns

Threshold: ac coupled
Only valid for external input

External input: Used for external started or gated

Input frequency: DC to 330MHz

Delay from external input to trigger output: 22ns + 0 to 1 period

Delay from external input to output:

Ordering Information - 81100 Family

The minimum configuration for a working instrument consists of a mainframe and one output module. The second output module can be added later. Output modules can be exchanged and retrofitted by the user. The Reference Guide (811xx-91021) is supplied with each mainframe for all configurations. A memory card is not included.

Each Agilent 81101A mainframe includes one output channel (in comparison to the other models of the Agilent 81100 family). The output module of the 81101A does not need to be ordered separately.

Agilent 81101A 50 MHz one channel Pulse Generator, 10V

Quick Start Guide language options

- Opt OBI** English Guide (811xx-91021)
- Opt ABF** French Guide (81101-91210)
- Opt ABJ** Japanese Guide (81101-91510)
- Opt ABO** Taiwan Chinese Guide (81101-91610)
- Opt AB1** Korean Guide (81101-91710)
- Opt AB2** Chinese Guide (81101-91810)

Additional documentation options

- Opt OBW** Service Manual (81101-91021)

All options are orderable with the mainframes.

Accessories

- Opt UN2** Rear Panel Connectors (instead of front panel)
- Opt 1CP** Rack Mount and Handle Kit (5063-9219)
- Opt 1CN** Handle Kit (5063-9226)
- Opt 1CM** Rack Mount Kit (5063-9212)
- Opt 1CR** Rack Slide Kit (1494-0059)
- Opt UFJ** 1 MB SRAM Memory Card (0950-3380)
- Opt UK6** Commercial cal. certificate with Test Data

Agilent 81104A

80 MHz Pulse/Pattern Generator Mainframe

Output module:

Agilent 81105A 80 MHz, 10 V

Agilent 81110A

330/165 MHz Pulse/Pattern Generator Mainframe

Output modules:

Agilent 81111A 165 MHz, 10 V

Agilent 81112A 330 MHz, 3.8 V

Note: Only use output modules of the same module number. A combination of the Agilent 81111A and Agilent 81112A in one Agilent 81110A is not possible.

Quick Start Guide language options

- Opt OBI** English Guide (811xx-91021)
- Opt ABF** French Guide (81110-91210)
- Opt ABJ** Japanese Guide (81110-91510)
- Opt ABO** Taiwan Chinese Guide (81110-91610)
- Opt AB1** Korean Guide (81110-91710)
- Opt AB2** Chinese Guide (81110-91810)

Additional documentation options

- Opt OBW** Service Manual (81110-91021)

Agilent 81130A

400/660 MHz Pulse/Data Generator Mainframe

Output modules:

Agilent 81131A 400 MHz, 3.8 V

Agilent 81132A 660 MHz, 2.4 V

Note: Only use output modules of the same module number. A combination of the Agilent 81131A and Agilent 81132A in one Agilent 81130A is not possible.

Quick Start Guide language options

- Opt OBI** English Guide (811xx-91021)
- Opt ABF** French Guide (81130-91220)
- Opt ABJ** Japanese Guide (81130-91520)
- Opt ABO** Taiwan Chinese Guide (81130-91620)
- Opt AB1** Korean Guide (81130-91720)
- Opt AB2** Chinese Guide (81130-91820)

Additional documentation options

- Opt OBW** Service Manual (81130-91021)
- Opt OB1** English Quick Start Guide (includes English Reference Guide)
- Opt ABJ** Japanese Quick Start Guide (includes English Reference Guide)
- Opt OB0** Does not include any Quick Start Guide (includes English Reference Guide)

Related Agilent Literature **Pub.No.**

Agilent Family of Pulse/Pattern Generators, Brochure **5980-0489E**

Radar Distance test to airborne planes Application Note **5968-5843E**

The Dual Clock Gbit Chip test Application Note **5968-5844E**

For more information, please visit us at www.agilent.com/find/pulse_generator

Product specifications and descriptions in this document subject to change without notice.

For the latest version of this document, please visit our website at www.agilent.com/find/pulse_generator and go to the Key Library Information area or insert the publication number (**5980-1215E**) into the search engine.



Agilent Email Updates

www.agilent.com/find/emailupdates
Get the latest information on the products and applications you select.



Agilent Direct

www.agilent.com/find/agilentdirect
Quickly choose and use your test equipment solutions with confidence.



Agilent Open

www.agilent.com/find/open
Agilent Open simplifies the process of connecting and programming test systems to help engineers design, validate and manufacture electronic products. Agilent offers open connectivity for a broad range of system-ready instruments, open industry software, PC-standard I/O and global support, which are combined to more easily integrate test system development.

Agilent Technologies' Test and Measurement Support, Services, and Assistance

Agilent Technologies aims to maximize the value you receive, while minimizing your risk and problems. We strive to ensure that you get the test and measurement capabilities you paid for and obtain the support you need. Our extensive support resources and services can help you choose the right Agilent products for your applications and apply them successfully. Every instrument and system we sell has a global warranty. Support is available for at least five years beyond the production life of the product. Two concepts underlie Agilent's overall support policy: "Our Promise" and "Your Advantage."

Our Promise

Our Promise means your Agilent test and measurement equipment will meet its advertised performance and functionality. When you are choosing new equipment, we will help you with product information, including realistic performance specifications and practical recommendations from experienced test engineers. When you use Agilent equipment, we can verify that it works properly, help with product operation, and provide basic measurement assistance for the use of specified capabilities, at no extra cost upon request. Many self-help tools are available.

Your Advantage

Your Advantage means that Agilent offers a wide range of additional expert test and measurement services, which you can purchase according to your unique technical and business needs. Solve problems efficiently and gain a competitive edge by contracting with us for calibration, extra-cost upgrades, out-of-warranty repairs, and onsite education and training, as well as design, system integration, project management, and other professional engineering services. Experienced Agilent engineers and technicians worldwide can help you maximize your productivity, optimize the return on investment of your Agilent instruments and systems, and obtain dependable measurement accuracy for the life of those products.

Phone or Fax

United States
(tel) 800 829 4444
(fax) 800 829 4433

Canada
(tel) 877 894 4414
(fax) 905 282 6495

China:
(tel) 800 810 0189
(fax) 800 820 2816

Japan:
(tel) (81) 426 56 7832
(fax) (81) 426 56 7840

Korea:
(tel) (080) 769 0800
(fax) (080)769 0900

Latin America:
(tel) (305) 269 7500

Taiwan:
(tel) 0800 047 866
(fax) 0800 286 331

Other Asia Pacific Countries:
(tel) (65) 6375 8100
(fax) (65) 6755 0042
Email: tm_ap@agilent.com

For more information on Agilent Technologies' products, applications or services, please contact your local Agilent office. The complete list is available at:

www.agilent.com/find/contactus

© Agilent Technologies 2005
Printed in the Netherlands, 14th November 2005

5980-1215E



Agilent Technologies