

Applications

Agilent fixed and step attenuators¹ find use in a wide variety of applications for signal conditioning and level control.

- Reducing signal levels
- Matching impedances of sources and loads
- Measuring gain or loss of a two-port device

Key specifications

- SWR
- Accuracy
- Repeatability
- Life

SWR

Most attenuators use some form of distributed thin-film attenuating element, designed to operate over multi-octave ranges and for low SWR match at input and output. The SWR characteristic is controlled with careful design of the element as well as the transition from RF connector to the element's planar geometry.

When an attenuator is inserted into a test network, the interaction of its SWR and the network SWR results in frequency-varying mismatch, which degrades the accuracy of the measurement. The amount of variation often exceeds the flatness specification of the attenuator. As an example, if at a given frequency, a 3 dB attenuator with SWR of 1.22 at each port is inserted into a microwave network that has a source and load SWR of 1.35, the variation from the expected 3 dB change could be as great as ± 0.5 dB. This change is due to SWR alone and points out the importance of the SWR specification in a precision attenuator.

Accuracy

The accuracy of an attenuator directly affects the uncertainty of the measurement where the attenuator is used. In many measurement and metrology applications, attenuators are the basic standard against which other components and instruments are calibrated.

Agilent attenuator accuracy specifications always include the effect of frequency response. And, Agilent attenuators use "edgeline" coaxial structure technology to achieve low-insertion loss and SWR resulting in better accuracy.

Agilent attenuators achieve flat-frequency response and high accuracy through the use of thin-film attenuator cards. These cards are composed of high-stability tantalum nitride resistive film, deposited on sapphire or alumina substrates. Advanced design and state-of-the-art processes in the deposition stages allow precise control of the geometry and thus the attenuation value. The result is very flat frequency response and greater accuracy.

Ultimate specified accuracy of RF/microwave attenuators is limited by the accuracy to which National Institute of Standards and Technology (NIST) can measure, plus the uncertainty of the measurement transfer process which calibrates the production test equipment. See Figure 1, on the next page, for an accuracy traceability example. At Agilent, performance to specifications is verified by fully testing each attenuator with an ATE system including an automatic network analyzer (ANA). In turn, the ANA is periodically calibrated using standards traceable to NIST.

Each published specification has been established using a "specification budget" process. This process provides for "guardbands" to account for transfer uncertainties between NIST, Agilent Metrology Labs, and the Agilent production test systems. Figure 2, on the next page, shows how the specification budget is allocated.

¹ See Waveguide chapter for additional products.

Repeatability

Fixed attenuators are often used as standards of reference in microwave measurements. Therefore, the accuracy of the measurement depends not only on the reference accuracy but on the repeatability of the insertion processes. Typical production test situations might require hundreds of connects/disconnects per day. So, measurement repeatability depends strongly on the connectors used. Agilent attenuators use precision type-N and APC-7 connectors, with repeatability that exceeds the International Electrotechnical Commission (IEC) standard for 7-mm connectors. For higher frequencies, Agilent uses 3.5-mm connectors that are fully SMA compatible, but are more rugged and repeatable than SMA. For applications to 50 GHz, Agilent uses 2.4-mm connectors that also have larger mating surfaces for rugged and repeatable connections. Design verification testing of 3.5-mm connectors showed virtually no test deterioration even after 1000 connections. For step attenuators, the repeatability of the internal RF connections is also of concern. Agilent uses an “edgeline” transmission line structure in which the outer conductor is a continuous ground plane and only the center conductor is switched to insert or remove an attenuation step. Keys to achieving long-term repeatability include precision control of all dimensions that affect contact pressure, careful selection and control of plating processes, and careful monitoring and control of the assembly process. The result is a step attenuator with repeatability specified at 0.03 dB maximum over 5 million cycles per section.

Life

The life of step attenuators is usually specified in cycles; i.e., the number of times a given attenuator section switches from one position to another and back. Agilent determines life by cycling attenuators to the point of degradation. Typically, Agilent attenuators in life cycle tests perform to specification for at least twice as many cycles as warranted. Agilent step attenuator families have a specified life of 5 million cycles per section (except the Agilent 355E,F). This long life results in lower cost of ownership by reducing periodic maintenance, downtime, and repairs.

Attenuators

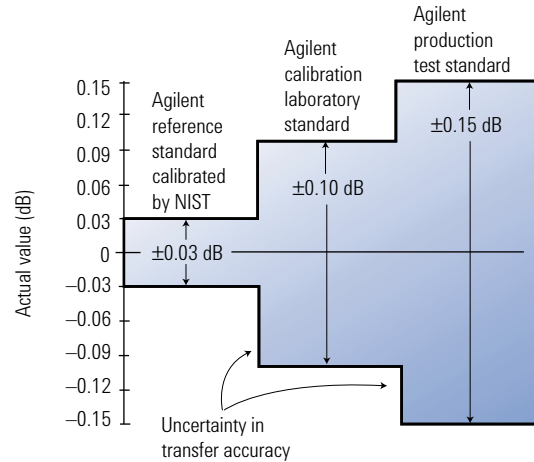

Figure 1. Accuracy traceability example.

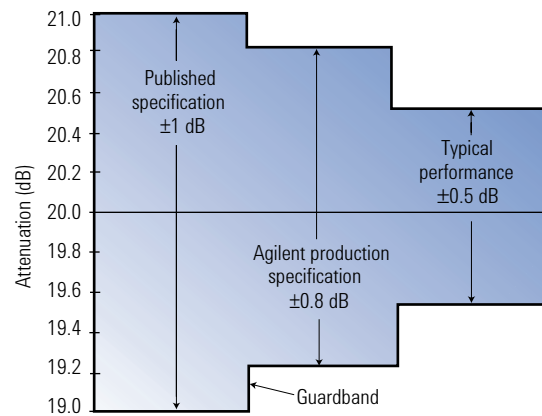

Figure 2. Guardband example.

Agilent 8490D



Agilent 8491A/B/C



Agilent 8492A



Agilent 8493A



Agilent 8498A



Agilent 8491A/B/C, 8492A, 8493A/B/C

Agilent Technologies coaxial fixed attenuators provide precise attenuation, flat frequency response, and low SWR over broad frequency ranges. Attenuators are available in nominal attenuations of 3 dB and 6 dB, as well as 10 dB increments from 10 dB to 60 dB. These attenuators are swept-frequency tested to ensure specification compliance at all frequencies. Calibration points are provided on a nameplate chart attached to each unit (except for the Agilent 8491C).

Agilent 8498A high-power attenuator

The Agilent 8498A Option 030 is designed to meet the needs of high-power attenuation applications in the RF and microwave frequency range. It is a 25 watt average, 30 dB fixed attenuator with a frequency range of dc to 18 GHz. The maximum peak power specification is 500 watts (dc to 5.8 GHz) and 125 watts (5.8 to 18 GHz). Available only in a 30 dB version, the unit offers a 1.3 SWR and ± 1 dB accuracy at 18 GHz. Large heat-dissipating fins keep the unit cool even under continuous maximum input power conditions.

Agilent 8490D 50 GHz fixed attenuator

Agilent Technologies coaxial fixed attenuators have been the standard for accurate flat response and low SWR. The Agilent 8490D offers exceptional performance to 50 GHz using the 2.4-mm connector. Attenuation values available are 3, 6, 10, 20, 30, and 40 dB. Ideally suited for extending the range of sensitive power meters or for use as calibration standards, these broadband attenuators are manufactured with the same meticulous care as their lower frequency counterparts.

Agilent 11581A, 11582A, 11583C attenuator sets

A set of four attenuators (3, 6, 10, and 20 dB) is furnished in a walnut accessory case. The Agilent 11581A set consists of Agilent 8491A attenuators; the Agilent 11582A set, Agilent 8491B attenuators; the Agilent 11583A set, Agilent 8492A attenuators; and the Agilent 11583C set, Agilent 8493C attenuators. These sets are ideal for calibration labs or where precise knowledge of attenuation and SWR is desired.

Agilent 86213A attenuator set

Provides a set of four, 3, 6, 10, and 20 dB, 75 ohm type-N attenuators in a walnut accessory case (Agilent 0955-0765, 0955-0766, 0955-0767, and 0955-0768), respectively. Used for reducing power and improving match. SWR is 1.12 to 1.3 GHz and 1.3 to 3 GHz. Attenuation accuracy is ± 0.5 dB.

Specifications

Agilent model	Frequency range (GHz)	Maximum input power	Option:	003	006	010	020	030	040	Connectors
				Atten.	3 dB	6 dB	10 dB	20 dB	30 dB	
8490D	dc to 50	1 W avg.	Attenuation: Min: 0 to 50 GHz Max: 0 to 26.5 GHz Max: 26.5 to 50 GHz	2.5	5.4	9.4	19.2	29.2	38.2	2.4 mm (m, f)
				3.9	6.9	10.9	21.3	31.3	42.5	
				4.8	7.8	11.3	21.7	31.7	42.5	
				1.15	1.15	1.15	1.15	1.15	1.08	
SWR:	Max: 0 to 26.5 GHz Max: 26.5 to 40 GHz Max: 40 to 50 GHz	1.25	1.25	1.25	1.25	1.25	1.15			
		1.45	1.45	1.45	1.45	1.45	1.25			

Specifications

Agilent model	Frequency range (GHz)	Maximum SWR	Maximum input power	Attenuation accuracy (± dB)								Connectors
				3 dB	6 dB	10 dB	20 dB	30 dB	40 dB	50 dB	60 dB	
8491A	dc to 12.4	1.2 to 8 GHz 1.3 to 12.4 GHz	2 W avg. 100 W peak	0.3	0.3	0.5	0.5	1.0	1.5	1.5	2	N (m, f)
				3 to 30 dB								
				40 to 60 dB								
8491B	dc to 18	1.2 to 8 GHz 1.3 to 12.4 GHz 1.5 to 18 GHz	2 W avg. 100 W peak	0.3	0.3 to 12.4 GHz 0.4 to 18 GHz	0.6	0.6 to 12.4 GHz 1.0 to 18 GHz	1.0	1.5	1.5	2	N (m, f)
				3 to 30 dB								
8491C	dc to 18	1.2 to 8 GHz 1.3 to 12.4 GHz 1.5 to 18 GHz	2 W avg. 100 W peak	0.3 to 12.4 GHz 0.4 to 18 GHz	0.4 to 12.4 GHz 0.5 to 18 GHz	0.6	0.6 to 12.4 GHz 1.0 to 18 GHz	1.0	—	—	—	N (m, f)
				3 to 30 dB								
8492A	dc to 18	1.15 to 8 GHz 1.25 to 12.4 GHz 1.35 to 18 GHz	2 W avg. 100 W peak	0.3	0.3 to 12.4 GHz 0.4 to 18 GHz	0.6	0.6 to 12.4 GHz 1.0 to 18 GHz	1.0	1.5	1.5	2	APC-7
				3 to 30 dB								
8493A	dc to 12.4	1.2 to 8 GHz 1.3 to 12.4 GHz	2 W avg. 100 W peak	0.3	0.3	0.5	0.5	1.0	—	—	—	SMA (m, f)
				3 to 20 dB								
8493B	dc to 18	1.2 to 8 GHz 1.3 to 12.4 GHz 1.5 to 18 GHz	2 W avg. 100 W peak	±0.3 dB	0.3 to 12.4 GHz 0.4 to 18 GHz	0.6	0.6 to 12.4 GHz 1.0 to 18 GHz	1.0	—	—	—	SMA (m, f)
				3 to 20 dB								
8493C	dc to 26.5	1.1 to 8 GHz 1.15 to 12.4 GHz 1.25 to 26.5 GHz ¹	2 W avg. 100 W peak	0.5 to 18 GHz 1.0 to 26.5 GHz	0.6	0.3	0.5	0.7	1.0	—	—	3.5 mm (m, f)
				3 to 30 dB								
8498A	dc to 18	1.15 to 8 GHz 1.25 to 12.4 GHz 1.30 to 18 GHz	25 W avg. 500 W peak (dc to 5.8 GHz) 125 W peak 500 W/ms max. per pulse (5.8 to 18 GHz)	—	—	—	—	1.0	—	—	—	N (m, f)
				30 dB								

¹1.27 for Option 006.

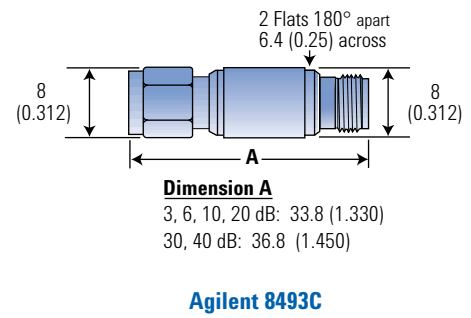
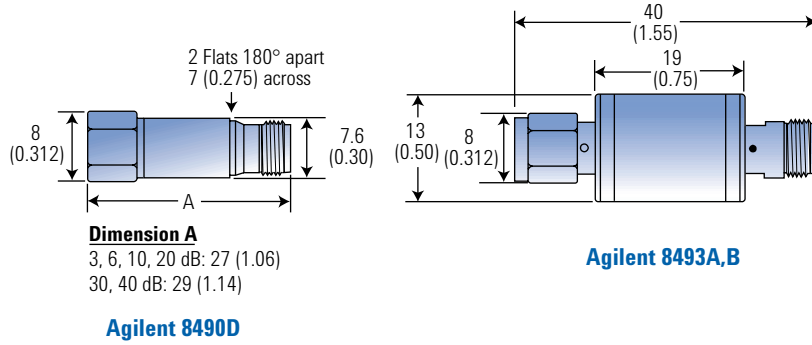

Dimensions are in mm (inches) nominal, unless otherwise specified.

Fixed attenuator ordering information

Agilent 8490/91/92/93/98 series ordering example ¹

<p>Agilent 849 3C</p> <p>Frequency range</p> <p>0D: dc to 50 GHz 1A: dc to 12.4 GHz 1B: dc to 18 GHz 1C: dc to 18 GHz 2A: dc to 18 GHz 3A: dc to 12.4 GHz 3B: dc to 18 GHz 3C: dc to 26.5 GHz 8A: dc to 18 GHz</p>	<p>Option 010</p> <p>Attenuation</p> <p>003: 3 dB 006: 6 dB 010: 10 dB 020: 20 dB 030: 30 dB 040: 40 dB² 050: 50 dB² 060: 60 dB²</p>	<p>Option UK6</p> <p>Calibration documentation</p> <p>UK6: Commercial calibration test data with certificate UKS: Commercial calibration certificate</p>
--	--	---

¹Each order must specify an attenuation option.

²Not available on all models. See specification table.

Step attenuator selection guide

	Step size	Attenuation range	Frequency range				
			dc to 1000 MHz	dc to 4 GHz	dc to 18 GHz	dc to 26.5 GHz	dc to 40 GHz
Manual	1 dB	0 to 11 dB		8494A	8494B		
		0 to 12 dB	355C				
Manual	10 dB	0 to 70 dB		8495A	8495B	8495D	
		0 to 110 dB 0 to 120 dB	355D	8496A	8496B		
Programmable	1 dB	0 to 11 dB		8494G	8494H	84904K	84904L
		0 to 12 dB	355E				
	0 to 70 dB		8495G	8495H	8495K 84907K	84907L	
	0 to 90 dB				8497K 84906K	84906L	
Programmable	10 dB	0 to 110 dB 0 to 120 dB	355F	8496G	8496H		

6

Agilent 355 series specifications

Manual	Agilent 355C	(0 to 12 dB, 1 dB steps)
	Agilent 355D	(0 to 120 dB, 10 dB steps)
Programmable	Agilent 355E	(0 to 12 dB, 1 dB steps)
	Agilent 355F	(0 to 120 dB, 10 dB steps)

Agilent 355C/D



The manual and programmable Agilent 355 series attenuators offer exceptional attenuation accuracy to 1 GHz; 0.1 dB to 1 kHz, 0.25 dB to 500 MHz, 0.35 dB to 1 GHz. They feature BNC (f) RF connectors, with optional type-N (Option 001) and TNC (Option 005) also available. To achieve 1 dB steps up to a range of 132 dB, serially connect two attenuators using a standard UG-491A/U BNC (m)-to-BNC (m) adapter. Programmable Agilent 355EF models feature a 7-pin connector. To protect your transistor driver against transients during the switching cycle, order Option 007 to install a protective diode between each solenoid and driver.

Agilent 84904L



Agilent 8494/95/96A/B/D



Agilent 8494/95/96G/H/K



Agilent 84904/906/907 series

This family of programmable step attenuators offers unmatched attenuation performance to 40 GHz. The K models brings superior accuracy and reliability to 26.5 GHz, and the L models offers unparalleled performance to 40 GHz.

Agilent step attenuators consist of 3 or 4 cascaded sections of specific attenuation values; e.g., 1, 2, 4, or 10, 20, 30, or 40 dB. Both families offer the selection, performance, accuracy, and reliability expected from Agilent: attenuation ranges of 11, 70, or 90 dB, 1 dB, and 10 dB step sizes, 5 million cycles per section and better than 0.03 dB repeatability. RF connector choices include precision 3.5 mm on the 26.5 GHz K models, and precision 2.4 mm or 2.92 mm on the L models. While the 2.92-mm connector format is compatible with both 3.5-mm and SMA connectors, Agilent Technologies recommends the more rugged 2.4-mm connectors.

Agilent programmable step attenuators feature electro-mechanical designs that achieve 20 milliseconds switching time, including settling time. The permanent magnet latching allows automatic interruption of the dc drive voltage to cut power consumption and simplify circuit design. They are equipped with 10-pin DIP sockets (m) and have optional interconnect cables available.

Agilent 8494/95/96/97 series

This family of manual step attenuators offers fast, precise signal-level control in three frequency ranges, dc to 4 GHz, dc to 18 GHz, and dc to 26.5 GHz. They feature exceptional repeatability and reliability in a wide range of frequency, attenuation, and connector options.

Attenuation repeatability is specified to be less than 0.03 dB (0.05 dB, 18 to 26.5 GHz) for 5 million cycles per section. This assures low-measurement uncertainty when designed into automatic test systems. Electromechanical step attenuators offer low SWR, low-insertion loss, and high-accuracy required by high-performance test and measurement equipment.

Precision-plated, leaf-spring contacts insert/remove attenuator sections (miniature tantalum nitride thin-film T-pads on sapphire and alumina substrates) from the signal path. Unique process controls and material selection ensure unmatched life and contact repeatability.

Programmable models

Miniature drive solenoids in the programmable models keep switching time, including settling, down to less than 20 milliseconds. Once switched, strong permanent magnets hold the solenoids (and attenuation value) in place. Current interrupts automatically disconnect solenoid current, simplifying driver circuit design, and minimizing heat dissipation. Programming is done through a 12-pin Viking socket or optional ribbon cables with DIP plugs. Automatic drive control is easy using the GPIB compatible Agilent 11713A or 87130A attenuator/switch driver and an external controller.

Programmable and Manual Step

Programmable driver instruments

Programmable drive options for step attenuators include the Agilent 11713A attenuator/switch driver, which permits users to easily integrate the attenuator into GPIB compatible automatic test systems. Also, see page 179 for product descriptions of the Agilent 87130A and 70611A (MMS) attenuator/switch drivers.

Interconnect cable selections include various connector and ribbon cable configurations to match user applications. Standard interconnect cables are described in the Attenuator Cables table on page 53.

Manual models

These models provide excellent performance with the simplicity and convenience of positive manual switching. A low-torque camshaft activates the insertion and removal of the attenuation sections. Positive detents and an attenuation-level indicator ensures quick and accurate control.

Attenuator interconnecting kits

To achieve 1 dB step resolution up to 81 dB, 101 dB or 121 dB, combine the Agilent 8494 with 8495/96/97 using the Agilent 11716A,B,C interconnect kits to cascade attenuators in series.

Specifications

Agilent model (switching mode)	Frequency range (GHz)	Attenuation range	Insertion loss @ 0 dB	Maximum SWR	Repeatability ¹ life	Maximum RF input power	Shipping weight
355C (Manual)	dc to 1	0 to 12 dB 1 dB steps	↑ 0.2 dB + 2.3 dB/GHz ↓	↑ 1.2 to 250 MHz 1.3 to 500 MHz 1.5 to 1 GHz ↓	↑ 0.03 dB max 0.5 million cycles per section ↓	↑ 0.5 W avg. 350 W peak ² (10 μs max.) ↓	↑ 1.4 kg (3 lb) ↓
355E (Programmable)	dc to 1	0 to 12 dB 1 dB steps					
355D (Manual)	dc to 1	0 to 120 dB 10 dB steps					
355F (Programmable)	dc to 1	0 to 120 dB 10 dB steps					
8494A (Manual)	dc to 4	0 to 11 dB 1 dB steps	↑ 0.6 dB + 0.09 dB/GHz ↓	1.5 1.5 to 8 GHz 1.6 to 12.4 GHz 1.9 to 18 GHz	↑ 0.03 dB max 5 million cycles per section ↓	↑ 1 W avg. 100 W peak ² (10 μs max.) ↓	↑ 0.9 kg (2 lb) ↓
8494G (Programmable)	dc to 4	0 to 11 dB 1 dB steps					
8494B (Manual)	dc to 18	0 to 11 dB 1 dB steps					
8494H (Programmable)	dc to 18	0 to 11 dB 1 dB steps					
8495A (Manual)	dc to 4	0 to 70 dB 10 dB steps	↑ 0.4 dB + 0.07 dB/GHz ↓	1.35 1.35 to 8 GHz 1.5 to 12.4 GHz 1.7 to 18 GHz	↑ 0.03 dB max to 18 GHz 0.05 dB max to 26.5 GHz 5 million cycles per section ↓	↑ 1 W avg. 100 W peak ² (10 μs max.) ↓	↑ 0.9 kg (2 lb) ↓
8495G (Programmable)	dc to 4	0 to 70 dB 10 dB steps					
8495B (Manual)	dc to 18	0 to 70 dB 10 dB steps					
8495H (Programmable)	dc to 18	0 to 70 dB 10 dB steps					
8495D (Manual)	dc to 26.5	0 to 70 dB 10 dB steps	↑ 0.5 dB + 0.13 dB/GHz ↓	1.6 to 6 GHz 1.6 to 12.4 GHz 1.9 to 18 GHz 2.2 to 26.5 GHz	↑ 0.03 dB max to 18 GHz 0.05 dB max to 26.5 GHz 5 million cycles per section ↓	↑ 1 W avg. 100 W peak ² (10 μs max.) ↓	↑ 0.9 kg (2 lb) ↓
8495K (Programmable)	dc to 26.5	0 to 70 dB 10 dB steps					
8496A (Manual)	dc to 4	0 to 110 dB 10 dB steps	↑ 0.6 dB + 0.09 dB/GHz ↓	1.5 1.5 to 8 GHz 1.6 to 12.4 GHz 1.9 to 18 GHz	↑ 0.03 dB max 5 million cycles per section ↓	↑ 1 W avg. 100 W peak ² (10 μs max.) ↓	↑ 0.9 kg (2 lb) ↓
8496G (Programmable)	dc to 4	0 to 110 dB 10 dB steps					
8496B (Manual)	dc to 18	0 to 110 dB 10 dB steps					
8496H (Programmable)	dc to 18	0 to 110 dB 10 dB steps					
8497K (Programmable)	dc to 26.5	0 to 90 dB 10 dB steps	0.4 dB + 0.09 dB/GHz	1.25 to 6 GHz 1.45 to 12.4 GHz 1.6 to 18 GHz 1.8 to 26.5 GHz	0.03 dB max to 18 GHz 0.05 dB max to 26.5 GHz 5 million cycles per section	↑ 1 W avg. 100 W peak ² (10 μs max.) ↓	↑ 0.9 kg (2 lb) ↓

¹ Measured at 25 °C. ² Not to exceed average power.

Agilent 355 series options

	Std.	Opt. 001	Opt. 005
RF connectors	BNC (f)	N (f)	TNC (f)
Drive circuit protection	Opt. 007: Protection diodes for Agilent 355E,F		

Agilent 8494/95/96/97 series options

	Std.	Opt. 011
Supply voltage		
Supply voltage range	20 to 30 Vdc	4.5 to 7 Vdc
Supply voltage (nom)	24 Vdc	5 Vdc
Current drawn	125 ma	300 ma
RF connectors		
A,B,G,H models	Opt. 001: N (f)	Opt. 002: SMA (f) Opt. 003: APC-7
K models	Opt. 004: 3.5 mm (f)	
DC connectors		
G,H,K models	Std: 12-pin Viking connector Opt. 008: 8-inch ribbon cable with 14-pin DIP plug Opt. 016: 16-inch ribbon cable with 14-pin DIP plug	
Calibration documentation	See ordering information	

Specifications

Agilent Model (switching mode)	Frequency range (GHz)	Attenuation range	Insertion loss (dB)	Maximum SWR Std. (Opt. 006)	Repeatability ¹ life	Maximum RF input power	Shipping weight
84904K (Programmable)	dc to 26.5	0 to 11 dB 1 dB steps	0.8 dB + 0.04 dB/GHz	1.3 (1.5) to 12.4 GHz	↑ 0.03 dB max. 5 million cycles per section ↓	↑ 1 W avg. 100 W peak ² (10 μs max) ↓	0.29 kg (10.32 oz)
84904L (Programmable)	dc to 40			1.7 (1.9) to 34 GHz 1.8 (2.0) to 40 GHz			
84906K (Programmable)	dc to 26.5	0 to 90 dB 10 dB steps	0.8 dB + 0.04 dB/GHz	1.3 (1.5) to 12.4 GHz			
84906L (Programmable)	dc to 40			1.7 (1.9) to 34 GHz 1.8 (2.0) to 40 GHz			
84907K (Programmable)	dc to 26.5	0 to 70 dB 10 dB steps	0.6 dB + 0.03 dB/GHz	1.25 (1.4) to 12.4 GHz			
84907L (Programmable)	dc to 40			1.5 (1.7) to 34 GHz 1.7 (1.9) to 40 GHz			

¹ Measured at 25 °C.

² Not to exceed average power.

Agilent 84904/906/907 series options

	Std.	Opt. 011	Opt. 015
Supply voltage			
Supply voltage range	20 to 30 Vdc	4.5 to 7 Vdc	13 to 22 Vdc
Supply voltage (nom)	24 Vdc	5 Vdc	15 Vdc
	125 mA	322 mA	187 mA
RF connectors			
K models	Std.: 3.5 mm (f)	Opt. 104: 3.5 mm (f) ³ 3.5 mm (m) ⁴	
L models	Std.: 2.4 mm (f)	Opt. 006: 2.92 mm (f)	Opt. 100: 2.4 mm (f) ³ 2.4 mm (m) ⁴ Opt. 106: 2.92 mm (f) ³ 2.92 mm (m) ⁴
Calibration documentation	See ordering information		

³ Drive cable end.

⁴ End opposite to drive cable.

Some Agilent attenuators were available as OEM equivalents to standard models. This table shows the corresponding model numbers.

Agilent Model Number	OEM Model Number	Agilent Model Number	OEM Model Number
8494A	33320A	8496H	33322H
8494B	33320B	8497K	33323K
8494G	33320G	84904K	33324K
8494H	33320H	84904L	33324L
8495G	33321G	84906K	33326K
8495H	33321H	84906L	33326L
8495K	33321K	84907K	33327K
8496G	33322G	84907L	33327L

OEM models of step attenuators are furnished without a base.

Outline Drawings

Agilent 84904/906/907 series – programmable

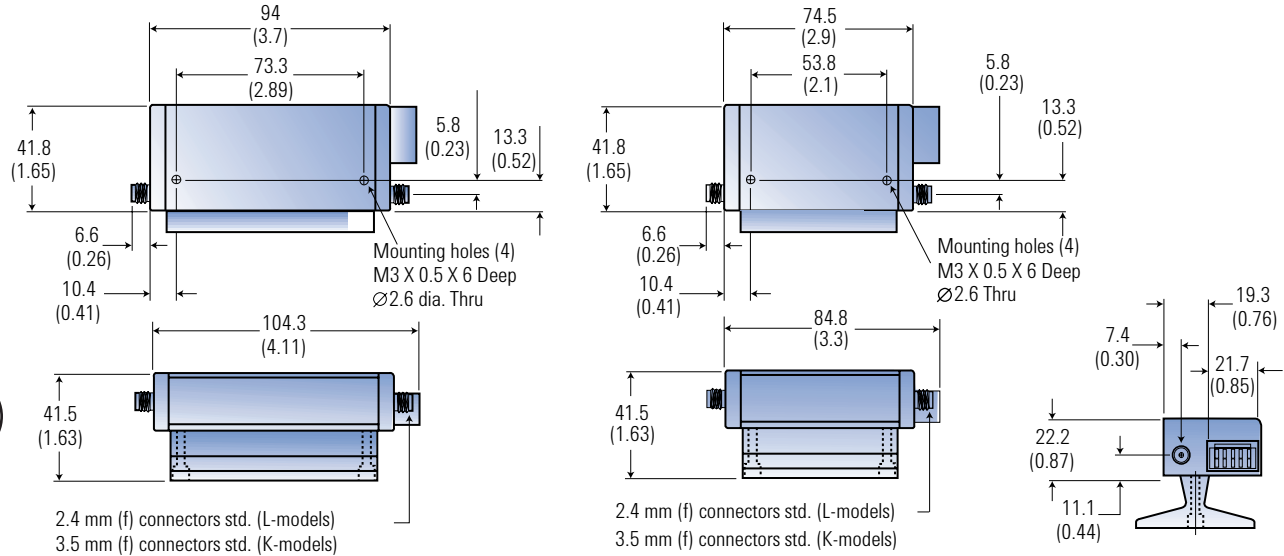

Agilent 8494/95/96/97 series – manual

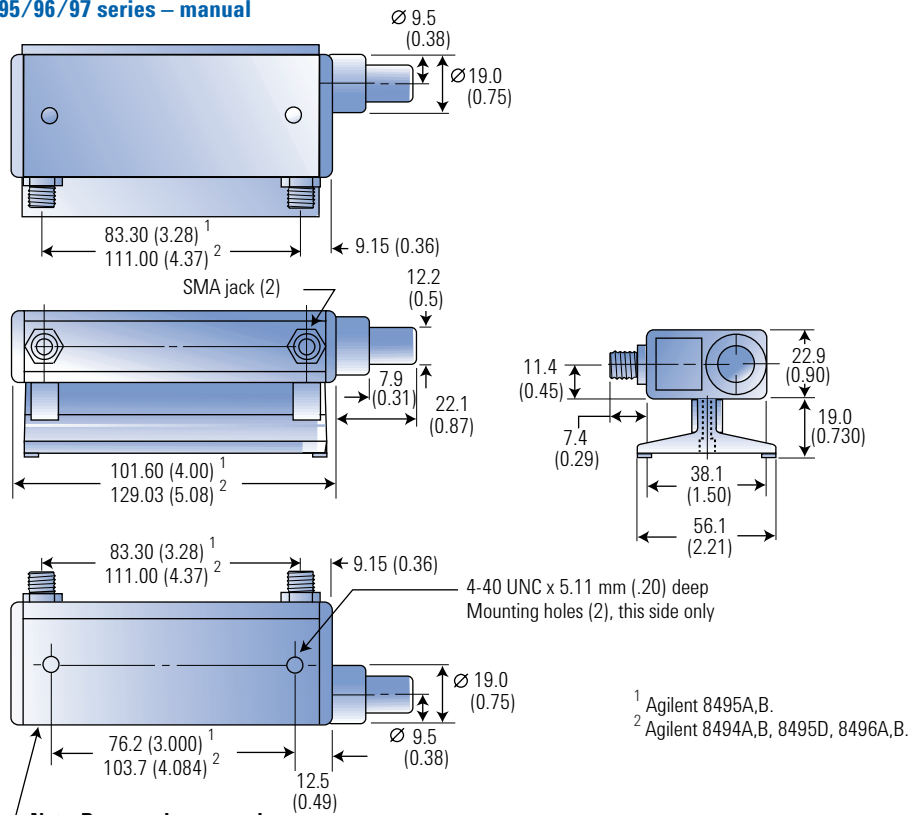

¹ Agilent 8495A,B.
² Agilent 8494A,B, 8495D, 8496A,B.

Dimensions are in mm (inches) nominal, unless otherwise specified.

Agilent 8494/95/96/97 series – programmable

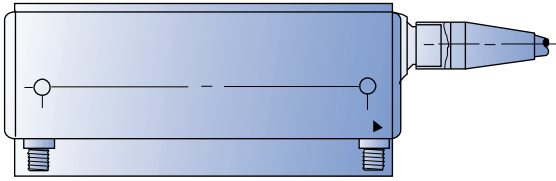

Solenoid drive plug and 5 ft. cable supplied, 6.3 (0.25) dia.

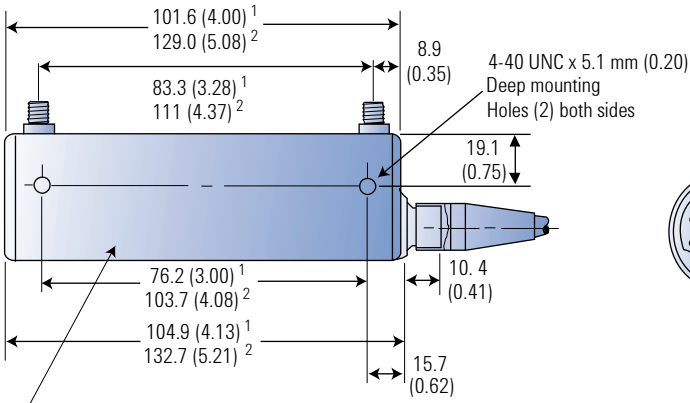
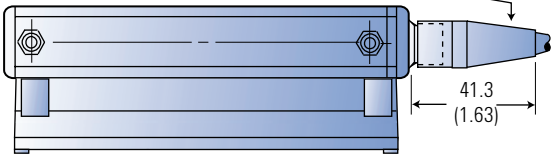

Note: Base can be removed by user to access mounting holes as shown above.

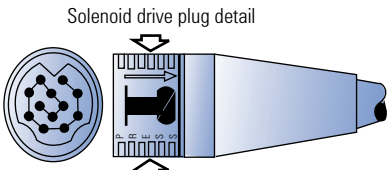
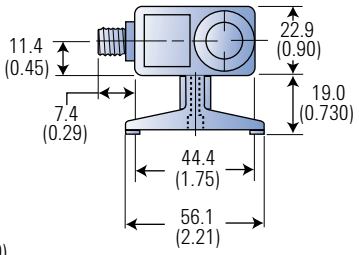

To remove: Press at arrows with thumb and finger, pull to detach. Caution: Do not twist.

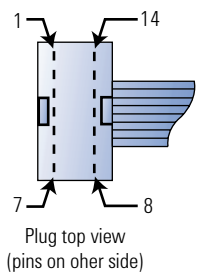
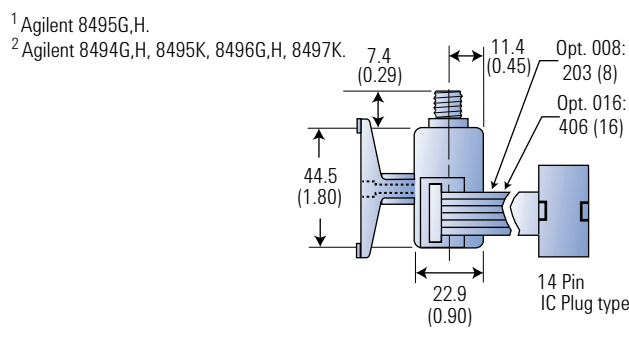

Dimensions are in mm (inches) nominal, unless otherwise specified.

Step attenuator ordering information

Agilent 355 series ordering example

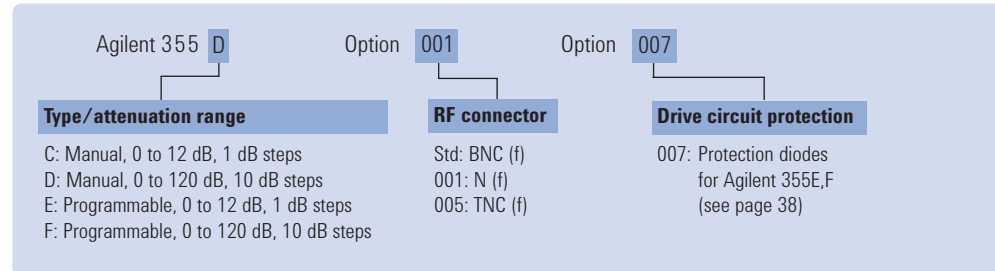

Agilent 8494/95/96/97 series ordering example

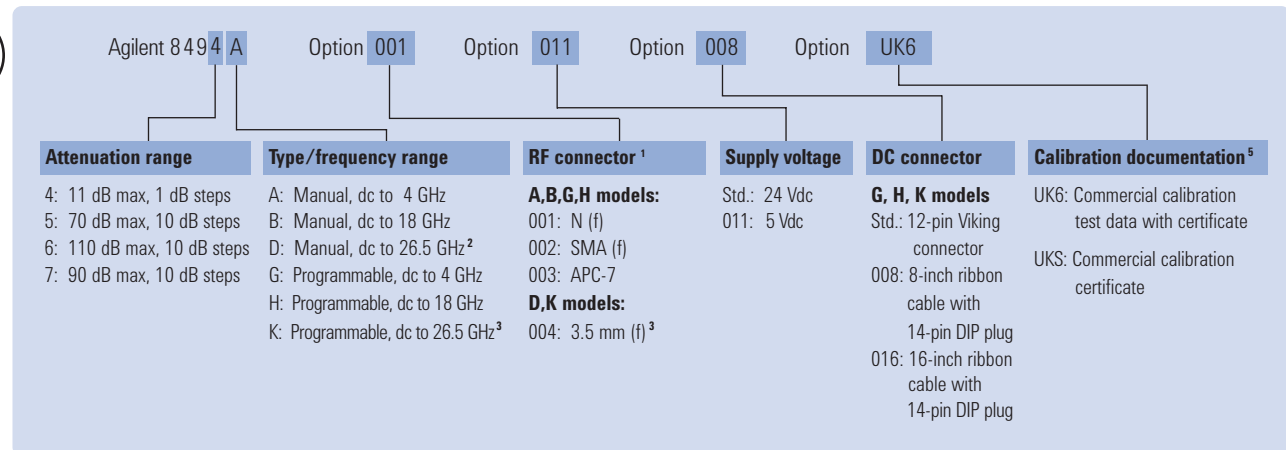

¹ Each order must include RF connector option.

² Available with Agilent 8495 only.

³ Available with Agilent 8495/97 only.

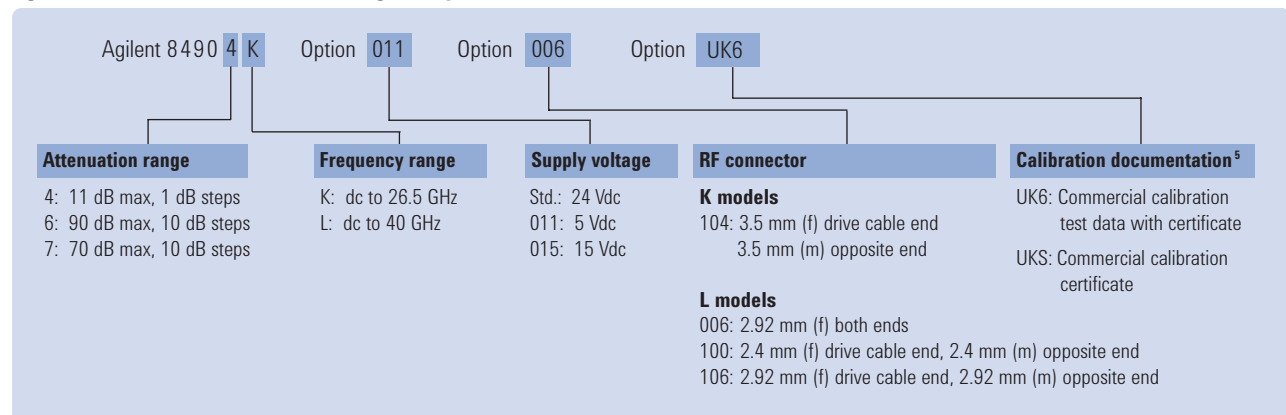
Agilent 84904/906/907 series ordering example ⁴

⁴ Drive cable not included. See Attenuator Cables table on next page.

⁵ Option UK6/UKS not available with Option 106.

Attenuator drive cables

Agilent model number	Agilent part number	Where used	Description
11764A		11713A to 84904/906/907	10-pin DIP to Viking conn., 60 inches
11764B		84904/906/907 to ribbon	10-pin DIP to 60 inch ribbon cable, bare leads
11764C		84904/906/907 to DIP	10-pin DIP to 14-pin DIP, 8-inch ribbon cable
11764D		84904/906/907 to DIP	10-pin DIP to 14-pin DIP, 16-inch ribbon cable
	11764-60005	84941A dist bd to 8494/95/96/97	Viking to (4) 4-pin Berg conn., 30 inches
	11764-60006	84941A dist bd to 84904/906/907	10-pin DIP to (4) 4-pin Berg conn., 30 inches
	70612-60017	84941A dist bd to 8494/95/96/97	Viking to (4) 4-pin Berg conn., 20 inches
	70612-60018	84941A dist bd to 84904/906/907	10-pin DIP to (4) 4-pin Berg conn., 20 inches

For complete cable configuration information, request publication number 5963-2038E, *Agilent 70611A, Agilent 87130A and Agilent 11713A Switch Attenuator Driver Configuration Guide.*

Attenuator/switch driver attenuator accessories

Agilent 11713A



Agilent 11713A attenuator/switch driver

This driver provides GPIB or “local” front panel drive control for programmable attenuators and electromechanical switches. Concurrently, drive up to two Agilent 8494/95/96 and Agilent 87904/906/907 programmable attenuators and two electro-mechanical switches (Agilent 8761, 8762, or 8765 series). The Agilent 11713A can also be used to supply +24V common and ten pairs of current sinking contacts (total current draw <1.25A peak for 1 sec., 0.65A steady state) to independently control up to 10 relays. An integral power supply (with short circuit protection) eliminates the need for an external power source. Each Agilent 11713A is supplied with two plug-in drive cables to simplify connection to programmable attenuators. Switching time is less than 10 milliseconds.

Agilent 11716A



Attenuator accessories

Agilent 11716 series attenuator interconnect kits

These kits can be utilized to connect any two of the Agilent 8494/95/96 attenuators in series. The rigid interconnect cable is available in type-N, APC-7, and SMA connectors as described below.

- Agilent 11716A Attenuator Interconnect Kit (type-N)
- Agilent 11716C Attenuator Interconnect Kit (SMA)