



Now...more choices for solving your measurement challenges

What's new in the 8720E family?

- **Transmission/reflection microwave analyzers**

The 8719ET, 8720ET, and 8722ET.

- **Electronic calibration made simpler**

Perform fast, accurate, automatic calibrations with Agilent's ECal products. Control ECal modules directly with the 85097A control unit without an external PC.

- **Enhanced response calibration**

Enhanced response calibration corrects for the effects of source match, unlike a simple response calibration, which does not correct for source match.

- **Easier-to-use four-parameter display**

All four display channels can be used without performing a full two-port calibration. Front panel keys for channels 3 and 4 make it easier to access the additional display channels.

- **Improved user interface**

Front panel keys also give you faster access to the **[Power]** menu and **[Marker Search]** functions. The **[Return]** key brings you quickly back to the prior menu.

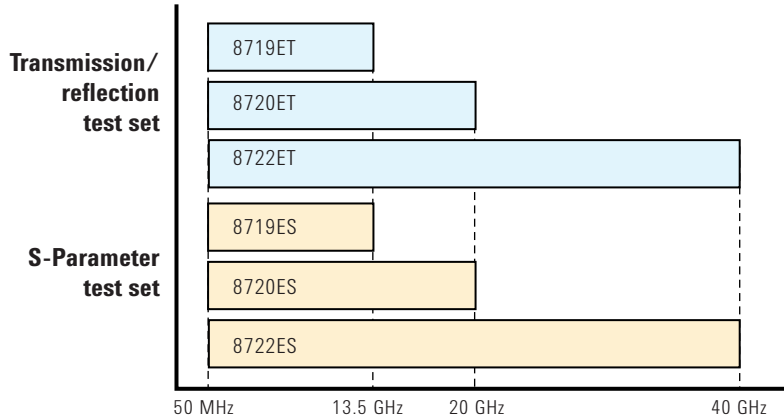

The Agilent Technologies 8720E family features six microwave vector network analyzers to increase your productivity. With the addition of the transmission/reflection analyzers (ET models), you can now choose from the traditional high-performance S-parameter analyzers (ES models), or the more economical ET models.

With S-parameter analyzers, you're able to measure the forward and reverse characteristics of components without disconnecting, turning around, and reconnecting them to the analyzer. The ES models also provide full 2-port calibration for excellent measurement accuracy.

The transmission/reflection analyzers provide forward transmission and reflection measurements of many devices, at an affordable price.

Both ET and ES models combine a fast, synthesized source with an integrated test set. These instruments quickly and accurately measure magnitude, phase, group delay and absolute power of transmission and reflection signals. So whether you want to improve your designs in R&D or maximize your measurement throughput in manufacturing, the 8720E analyzers can help by providing superb measurement accuracy, fast measurement speed, and thoughtfully-designed productivity features.

Solutions to your daily challenges

Minimize test time

The 8720E family provides rapid sweep speeds for real-time tuning. With fast register recalls and data transfer speeds, you'll minimize test time.

Measure and display all four S-parameters

The 8720E family has two independent measurement channels. Each measurement channel can have its own stimulus parameters, such as start and stop frequencies and number of points. View the measurement results on one of four display channels in split or overlaid mode on the built-in color LCD. Or use the VGA-compatible display output to drive a larger external monitor. You can display any combination of reflection and transmission parameters in magnitude, phase, group delay, Smith chart, polar, SWR, or time-domain formats.

Power to the network analyzer

An Agilent 8720E family network analyzer captures key measurement data; Agilent IntuiLink software allows that data to be put to work effortlessly. IntuiLink provides easy access to measurement data and images from *within* your standard PC applications. You work in a familiar environment at all times, using PC applications such as Microsoft Excel® or Word® to transfer, display, print, and document the data you get from the network analyzer. The IntuiLink application toolbar makes it easy, providing a simple way to download data and screenshots into a spreadsheet or document. Programmers can use ActiveX to control instruments directly using high-level toolbar functions. IntuiLink brings the barriers down, simplifying the way you do your job. For additional information, go to: www.agilent.com/find/IntuiLink



Improve your measurement accuracy with a variety of calibrations

The 8720E family offers a variety of calibration types. The enhanced response calibration provides improved accuracy over a simple response calibration. The ES models offer full two-port calibration for optimum accuracy. Use short-open-load-through calibration in coaxial environments, or TRL*/LRM* calibration for non-coaxial environments such as microstrip fixtures. Adapter-removal calibration is available on the ES models to provide improved accuracy for measuring most noninsertable devices.

Leverage your current investment

The 8719ES, 8720ES and 8722ES models have GPIB commands and front-panel features that are compatible with the 8719D, 8720D, and 8722D. This backward compatibility means you can easily transition to the new models while leveraging your investment in software and operator training.¹ The ET models have a more limited feature set than the ES models, but you will find them very similar to the ES models and just as easy to use.

1. Agilent strives to achieve the highest degree of backward compatibility; however, full backward compatibility is not guaranteed.



Expand your measurement capabilities with these options²

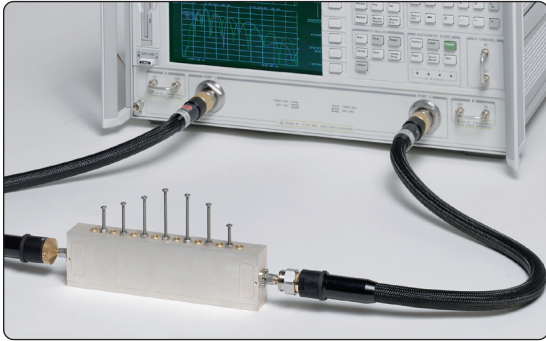

Tune cavity-resonator filters in time-domain.

Analyze devices and tune filters in time-domain with Option 010

The time-domain option (Option 010) converts the frequency domain data to time-domain using an inverse Fourier transform. You can use time-domain to locate and resolve most mismatches in your device, fixture, or cable. Once located, use gating to remove unwanted responses.

Combining an S-parameter analyzer with the time-domain capability provides a simple, deterministic method for tuning cavity-resonator bandpass filters. Comparing the filter's reflection response in the time-domain with the response of a properly tuned filter reveals which resonators or coupling adjustments need to be tuned. With time-domain filter tuning, you can more easily train new personnel for this complex task, and greatly simplify the fine-tuning and troubleshooting procedures.

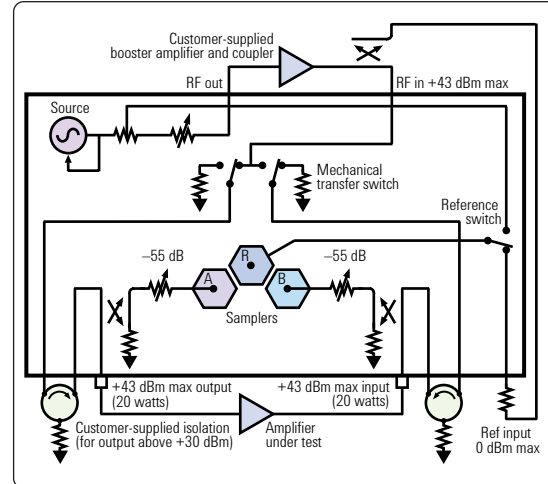

Measure high-power amplifiers.

Measure high-power devices with Option 085 (ES models only)

Option 085 is used for measuring high-power amplifiers up to 20 watts. A mechanical switch is added to the reference path so you can add your own external amplifier to boost the input power to your device. To protect the analyzer from high power levels, Option 085 includes internally controlled step attenuators in the receiver path, and RF loops that allow you to insert isolators.

2. Most options are available for an extra charge.



Configurable test set for a range of measurements.

Extend receiver dynamic range with Option 012 (ES models only)

Option 012 provides front-panel access to the receivers. This allows transmission measurements that bypass the coupler for improved signal-to-noise ratio. So you can make antenna measurements to -110 dBm at 40 GHz, and filter rejection measurements to 116 dB. Use the RF loop to add a 20-dB attenuator to increase the test port compression level.

For information about test fixtures, contact:

Inter-Continental Microwave

1515 Wyatt Drive
Santa Clara, CA 95054 USA
Telephone: (408) 727-1596
Fax: (408) 727-0105
website: www.icmicrowave.com
E-mail: icmfixture@aol.com

For information about probing equipment and accessories contact:

Cascade Microtech, Inc.

2430 NW 206th Avenue,
Beaverton, OR 97006 USA
Telephone: (503) 601-1000
Fax: (503) 601-1002
website: www.cascademicrotech.com
E-mail: sales@cmicro.com

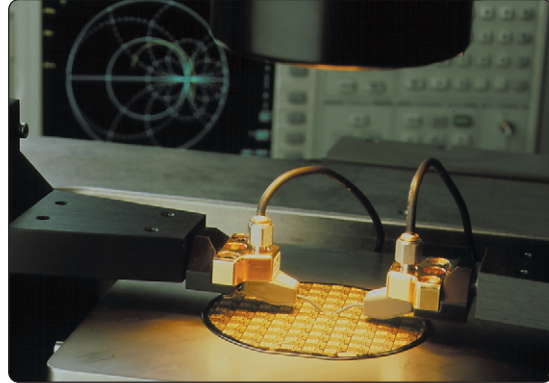

TRL calibration provides the highest accuracy for in-fixture and on-wafer measurements.

Calibrate in-fixture or on-wafer test systems with Option 400 (ES models only)

Through-Reflect-Line (TRL) calibrations use standards that are simple and easy to fabricate and characterize, and provide the ultimate in accuracy. Perform a TRL* calibration with standard analyzers, or add a fourth receiver (Option 400) and perform a true TRL calibration.

Extend source power range with Option 004 (ET models only)

Option 004 adds a step attenuator to the source, extending the power range in the ET models by 55 dB. Depending on the frequency, the power range extends from -70 to $+5$ dBm.

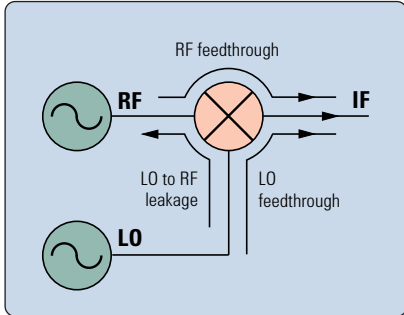

Test mixers with frequency offset mode (ES models only)

Option 089 frequency offset mode lets the analyzer's source and receiver operate at different frequencies. Use this feature to measure mixer conversion loss; the analyzer's source sweeps the RF and the swept IF is measured by the receiver. For many fixed IF measurements, automatic test sequencing can control external RF and LO sources over GPIB. Power meter calibration and receiver calibration can be used to greatly improve the accuracy of the measurement.

Measure power precisely with power meter calibration

Frequency and power sweeps enable the Agilent 8720E analyzers to measure gain, return loss, reverse isolation, gain compression, and AM-PM conversion of amplifiers. Power meter calibration transfers the accuracy of the power meter to your network analyzer. Using an 8720E analyzer, you can measure gain compression or output power with exceptional accuracy.

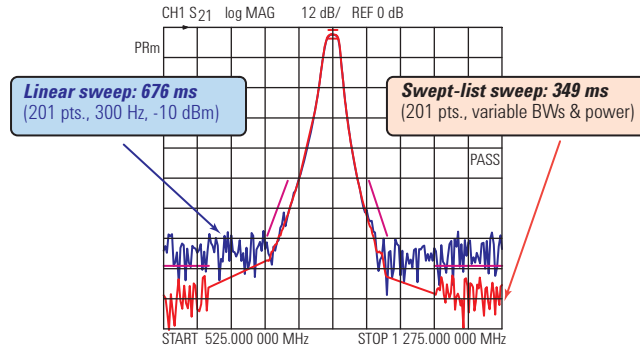

A filter measurement made using swept-list mode with five customized sweep segments can be much faster than using simple linear frequency sweep.

Optimize throughput and accuracy with swept-list frequency mode

This feature lets you define a sweep as a series of segments. Each segment has its own frequency range, number of points, IF bandwidth, and power level. List-frequency sweeps can improve throughput dramatically since the analyzer can sweep quickly (using wide IF bandwidths) through segments where high dynamic range is not needed. Narrow IF bandwidths are used only in segments where high dynamic range is critical.

Select from a variety of sweep modes

When fast measurement speed is critical, use the frequency sweep mode. For ultimate frequency accuracy, combine the high-frequency-stability option (Option 1D5) with stepped frequency mode. Choose power sweep mode to characterize the nonlinear behavior (such as amplifier gain compression) of most devices.



Reduce calibration time with ECal

Agilent's electronic calibration (ECal) products provide easy, fast and accurate calibrations. ECal uses firmware control, an interface unit and ECal modules in a variety of connector types, including 3.5-mm, 7-mm, and 50-ohm Type-N. This easy-to-use solution helps reduce operator errors and connector damage, and provides accurate calibrations for most non-insertable devices, helping improve product yields.

Automate repetitive tasks with test-sequencing

You can set up a simple test sequence by making a measurement while the network analyzer records the keystrokes. Later, repeat the entire sequence by pressing a single key. Because the sequence is defined with normal measurement keystrokes, you do not need additional programming expertise. Test sequencing also allows you to display user prompts, make decisions during a test and branch to other sequences, control other GPIB instruments, or use the parallel port to control test sets or part handlers.



Agilent custom test sets help simplify your measurement.

Let Agilent design and build a custom test set for you

If your application requires a special configuration, ask us about our special options, which offer a wider range of specifications. For example, Option H16 adds a switch that allows the analyzer to be used either in the standard test set configuration or in low-noise-floor mode.

Link to your CAE program

Use electronic design programs such as Agilent's EEsof Advanced Design System (ADS) in conjunction with the 8720E family of analyzers to help optimize the performance of your device, and generate and import device models. You can store ASCII data files to disk in conformance with CITIFILE or Touchstone-compatible (S2P) formats for importing to your design software. Agilent's EEsof programs can also transfer data to and from the network analyzer via GPIB.



The Agilent 8720E family at-a-glance

Features	ET models	ES models
Transmission/reflection test set	X	
S-parameter test set		X
Error correction	ET models	ES models
One-port calibration	X	X
Enhanced response calibration	X	X
Full two-port calibration		X
TRL*/LRM* calibration ³		X
TRL/LRM calibration ⁴		X
Options	ET models	ES models
Step attenuator (Option 004)	X	standard
Mechanical transfer switch (Option 007)	not applicable	X
Time-domain (Option 010)	X	X
Direct receiver access (Option 012)		X
High-power test set (Option 085)		X
Frequency offset mode (Option 089)		X
Fourth sampler and TRL calibration firmware (Option 400)		X
High-stability frequency reference (Option 1D5)	X	X

³ A modified version of TRL/LRM for the three-receiver test set.

⁴ Requires Option 400, which adds a fourth receiver and special firmware.

Agilent expertise at your service

Quality and reliability

The 8720E family of network analyzers is manufactured in ISO 9002-registered facilities in concurrence with Agilent's renowned commitment to quality. We put our network analyzers through extensive environmental tests for shock, vibration, and extreme temperature cycling so that you can count on them.

Three-year global warranty

Our commitment to quality is backed by a standard three-year return-to-Agilent warranty. Support options to cover periodic calibrations are also available.

Agilent on the World Wide Web

8720E information: www.agilent.com/find/8720

Application Notes: www.agilent.com/find/tmapnotes

Other 8720E family literature

8720E Family Data Sheet 5968-5163E

8720E Family Configuration Guide 5968-5162E

Agilent Technologies' Test and Measurement Support, Services, and Assistance

Agilent Technologies aims to maximize the value you receive, while minimizing your risk and problems. We strive to ensure that you get the test and measurement capabilities you paid for and obtain the support you need. Our extensive support resources and services can help you choose the right Agilent products for your applications and apply them successfully. Every instrument and system we sell has a global warranty. Support is available for at least five years beyond the production life of the product. Two concepts underlie Agilent's overall support policy: "Our Promise" and "Your Advantage."

Our Promise

"Our Promise" means your Agilent test and measurement equipment will meet its advertised performance and functionality. When you are choosing new equipment, we will help you with product information, including realistic performance specifications and practical recommendations from experienced test engineers. When you use Agilent equipment, we can verify that it works properly, help with product operation, and provide basic measurement assistance for the use of specified capabilities, at no extra cost upon request. Many self-help tools are available.

Your Advantage

"Your Advantage" means that Agilent offers a wide range of additional expert test and measurement services, which you can purchase according to your unique technical and business needs. Solve problems efficiently and gain a competitive edge by contracting with us for calibration, extra-cost upgrades, out-of-warranty repairs, and on-site education and training, as well as design, system integration, project management, and other professional services. Experienced Agilent engineers and technicians worldwide can help you maximize your productivity, optimize the return on investment of your Agilent instruments and systems, and obtain dependable measurement accuracy for the life of those products.

Get assistance with all your test and measurement needs at: www.agilent.com/find/assist

Product specifications and descriptions in this document subject to change without notice.

Copyright © 1999, 2001 Agilent Technologies
Printed in U.S.A. February 20, 2001
5968-5161E

Windows is a U.S. registered trademark of Microsoft Corp.



Agilent Technologies

Innovating the HP Way