

# R&S® SMW200A

## Vector Signal Generator

### The fine art of signal generation

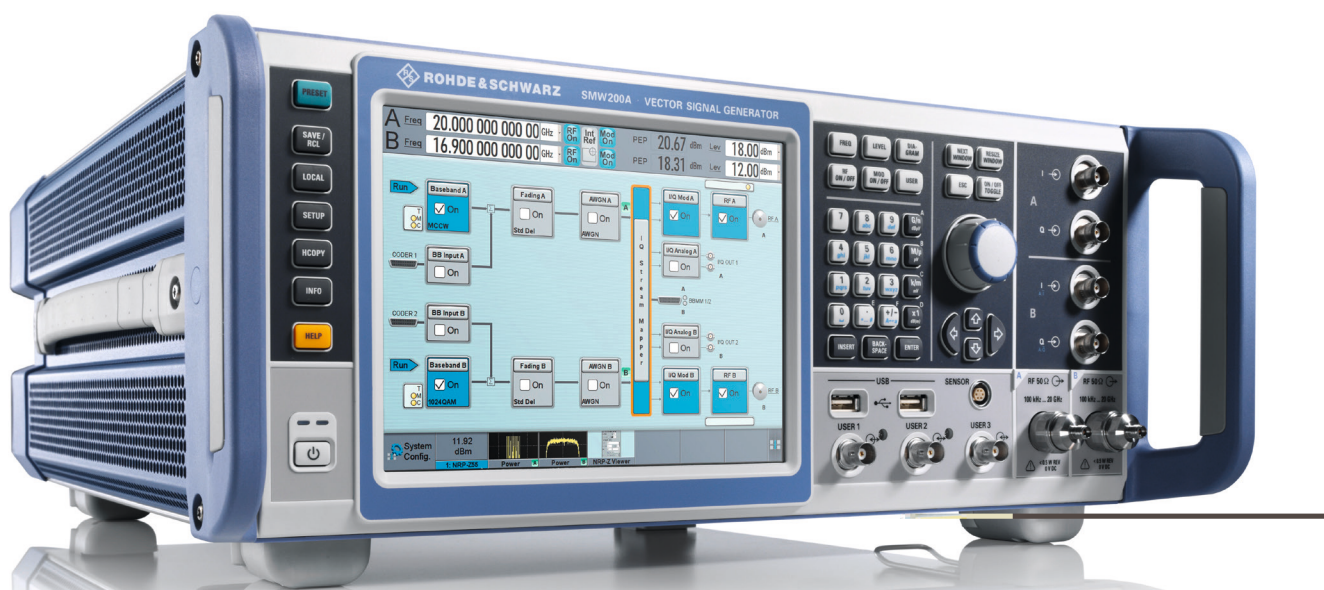

# R&S®SMW200A Vector Signal Generator At a glance

The R&S®SMW200A is the vector signal generator for the most demanding applications. As a result of its flexibility, performance and intuitive operation, it is a perfect tool for generating complex, digitally modulated signals of high quality.

The R&S®SMW200A is the ideal generator for digitally modulated signals required for the development of new wideband communications systems, the verification of 3G and 4G base stations or in the aerospace and defense sector.

The I/Q modulation bandwidth of up to 160 MHz with internal baseband satisfies fourth-generation standards (e.g. LTE-Advanced and IEEE 802.11ac), and the R&S®SMW200A is designed to meet future requirements. Its modular scalable architecture allows users to optimize the generator to their applications and to upgrade it as required.

A second RF path can be added, as well as a maximum of two baseband and four fading simulator modules – without compromising signal quality. As a result, the R&S®SMW200A can create signal scenarios that previously required multiple instruments or could not be implemented at all. From MIMO up to 8x2 and LTE-Advanced carrier aggregation including fading to multistandard radio – never before has an instrument offered such high-class signal generation capability.

If more than two RF paths are required, additional R&S®SGMA signal generator modules can be connected. The intuitive, touchscreen-based operating concept provides the user with an overview of measurements, no matter how complex, and quickly delivers the desired results.

## Key facts

- Frequency range from 100 kHz to 3 GHz, 6 GHz, 12.75 GHz, 20 GHz, 31.8 GHz or 40 GHz
- Optional second RF path with 100 kHz up to 3 GHz, 6 GHz, 12.75 GHz or 20 GHz
- Up to 160 MHz I/Q modulation bandwidth (in RF) with internal baseband
- Options for all important digital communications standards
- Optional integrated fading simulator with up to 160 MHz bandwidth
- Support of all key MIMO modes including 3x3, 4x4, 8x2, 2x8 and 4x2x2
- Intuitive operation via touchscreen with block diagram as key element

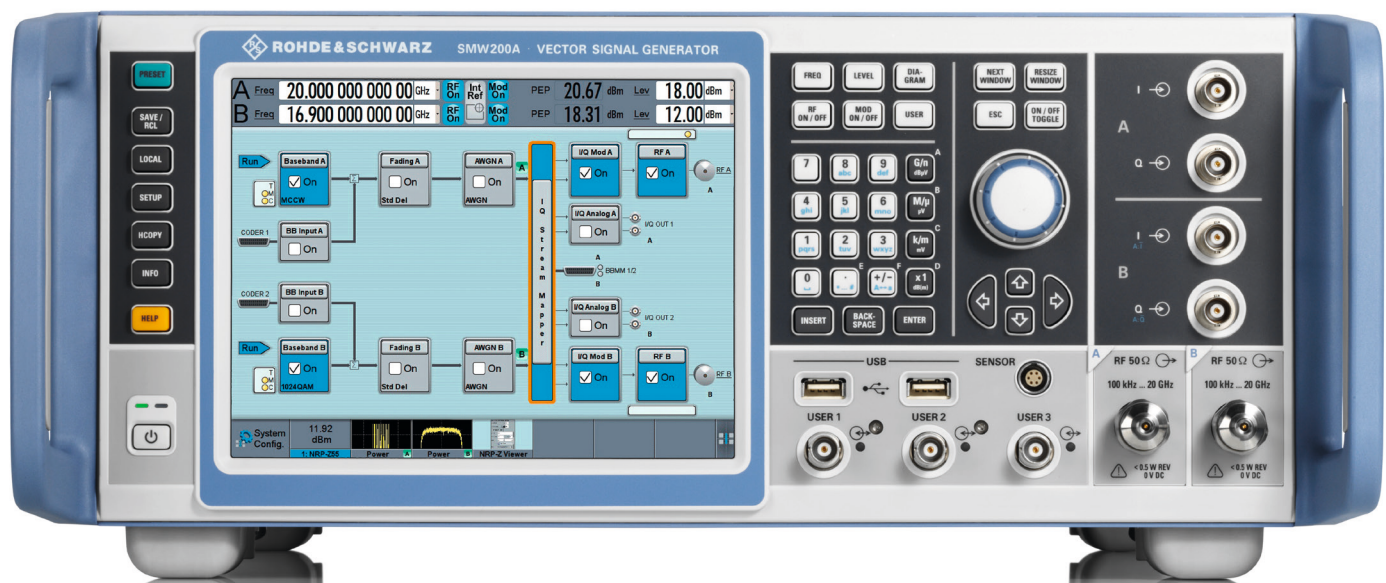

# R&S®SMW200A

## Vector Signal Generator

### Benefits and key features

#### For all your needs

- Frequency range from 100 kHz to 3 GHz, 6 GHz, 12.75 GHz, 20 GHz, 31.8 GHz or 40 GHz
- Optional second RF path with 100 kHz up to 3 GHz, 6 GHz, 12.75 GHz or 20 GHz
- Versatile configuration: from single-path vector signal generator to multichannel MIMO receiver tester
- Ideal for MIMO, MSR or LTE-Advanced applications thanks to up to eight signal sources and up to 16 fading channels
- Modular architecture for optimal adaptation to the application at hand

▷ [page 4](#)

#### Simplify your setup

- Easy generation of complex signals
- Max. eight baseband generators on two internal baseband modules with realtime coder and ARB
- Internal digital adding of baseband signals, even with frequency and level offset
- Support of all important digital standards such as LTE (up to Release 11), 3GPP FDD/HSPA/HSPA+, GSM/EDGE/EDGE Evolution, TD-SCDMA, CDMA2000®/1xEV-DO, WLAN IEEE 802.11 a/b/g/n/j/p/ac
- No separate PC software required for digital standards
- LTE and 3GPP test case wizards for easy base station conformance testing in line with 3GPP TS 25.141 or 3GPP TS 36.141
- Envelope tracking and AM/AM, AM/φM predistortion options for full testing and verification of ET modulator chipsets

▷ [page 6](#)

#### Bring reality to your lab

- Optional integrated fading section for channel emulation with up to 160 MHz bandwidth
- All important fading scenarios available as presets
- Installation of up to four fading modules, providing as many as 16 "logical" faders

- Implementation of all key MIMO fading scenarios such as 2x2, 3x3, 4x4, 8x2 and 2x8 using a single instrument
- Support of complex applications such as dual-carrier HSPA, LTE carrier aggregation with MIMO and multi-user LTE
- Connection of R&S®SGT100A signal generator modules to provide up to eight RF paths

▷ [page 10](#)

#### Make your device even better

- Excellent signal quality for high accuracy in spectral and modulation measurements
- I/Q modulator with up to 2 GHz RF modulation bandwidth
- 160 MHz I/Q modulation bandwidth (in RF) with internal baseband
- Exceptional modulation quality, e.g. -49 dB EVM (meas.) with 160 MHz wide WLAN IEEE 802.11ac signals
- High-end pulse modulation with on/off ratio > 80 dB and rise/fall time < 10 ns
- Excellent spectral purity (SSB phase noise -139 dBc (typ.) at 1 GHz, 20 kHz offset)
- Phase coherence option, e.g. for beamforming applications
- 3 GHz, 6 GHz and 12.75 GHz RF paths with electronic attenuator

▷ [page 12](#)

#### Speed up your development

- Intuitive operating concept and clever help functions for quick success
- Block diagram as key operating element to visualize signal flow
- Adaptive GUI for overview of both simple and complex scenarios
- Graphical signal monitoring at practically every point in the signal flow
- Context-sensitive online help system with complete user documentation
- SCPI macro recorder and code generator for generating executable remote control code from manual operating steps (for MATLAB®, CVI, etc.)

▷ [page 16](#)

#### Grows with your needs

- Customizing of instrument to accommodate virtually every application
- Advanced plug-in system for retrofitting baseband modules without instrument recalibration
- Software upgrades possible at any time, simple and quick activation via key codes

▷ [page 18](#)

# For all your needs

Advanced RF measuring equipment must, above all, be flexible. Performance and functionality requirements vary depending on test setup and application. The R&S®SMW200A is unrivaled in mastering this challenge and sets new standards for signal generators. In development and verification, for any type of DUT (components, modules, complete base stations) – the R&S®SMW200A always generates the appropriate test signals.

## Versatile configuration

Thanks to its modular design, the R&S®SMW200A can be equipped with the exact options required for a specific application. Any configuration is possible, from a classic single-path vector signal generator to a multichannel MIMO receiver tester.

The generator can be equipped with a maximum of two internal baseband modules and four fading simulator modules. It is also possible to install a second RF path. This concept yields two full-featured vector signal generators in a single unit, so that even complex signal scenarios (e.g. wanted signal + interferer, dual cell, TX/RX diversity) can be created easily.

## Ideal for MIMO, MSR or LTE-Advanced applications

And that is by far not all. The capabilities of the R&S®SMW200A surpass those of two conventional generators combined. When the instrument is fully equipped, the baseband section provides up to eight independent signal sources and up to 16 logical faders. This makes the R&S®SMW200A ideal for MIMO and other complex applications encountered in LTE-Advanced (carrier aggregation), HSPA (dual carrier) and multistandard radio, etc.

## Modular architecture for optimal adaptation to the application at hand

Almost all options of the R&S®SMW200A can be retrofitted, most of them simply via key code. Starting from the basic configuration as a classic single-path vector signal generator, the R&S®SMW200A can be customized as required for any application. Users only have to purchase what they currently need and are free to decide on upgrades according to their future requirements.

### Basic R&S®SMW200A architecture

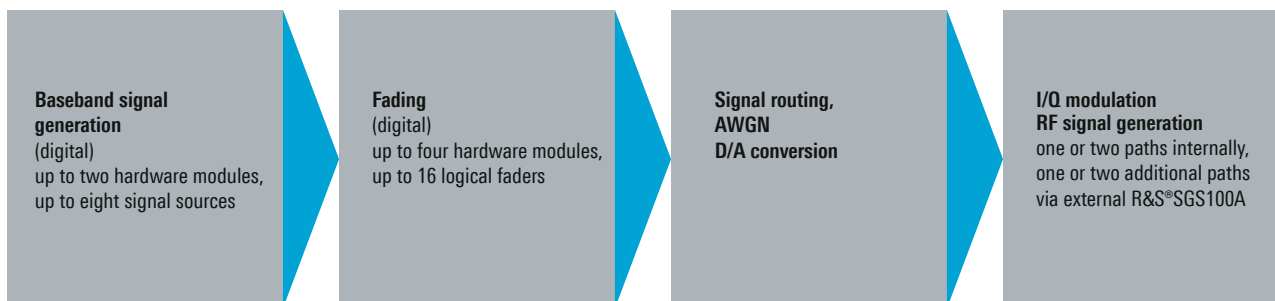

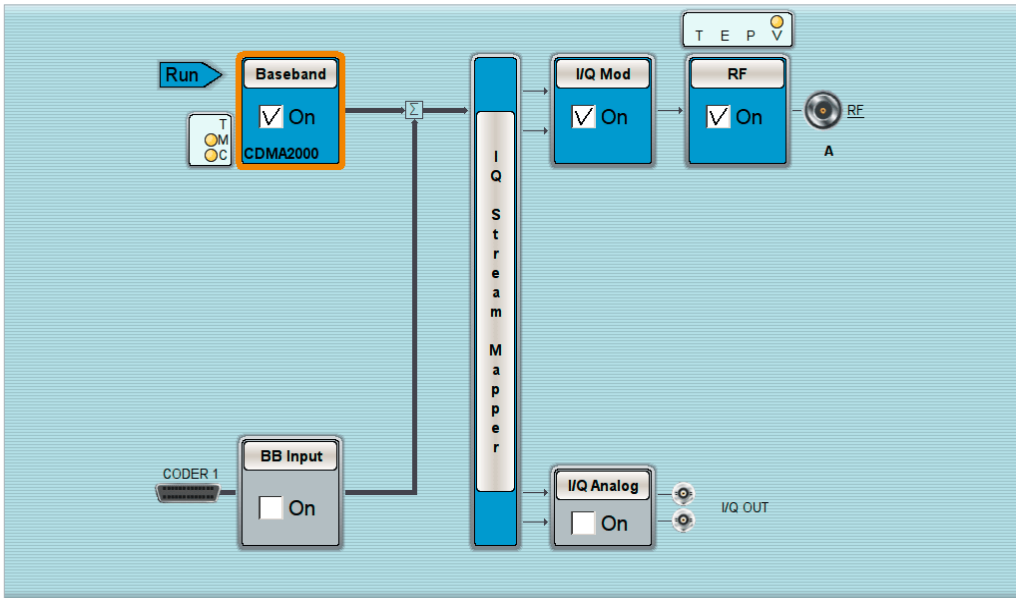

Configuration example 1:  
A single-path R&S®SMW200A with internal baseband can be used for measurements on components or for fundamental receiver testing.

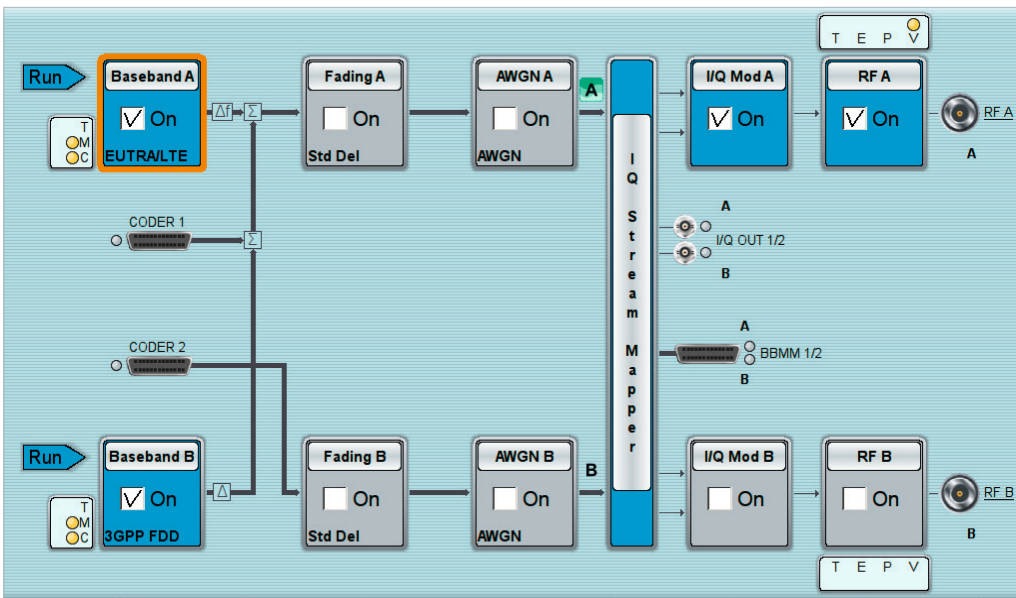

Configuration example 2:  
A two-path R&S®SMW200A is ideal for receiver and performance tests on base stations. One generator can generate the wanted signal plus interferer (in this example, a wanted LTE signal and a 3GPP FDD interferer).

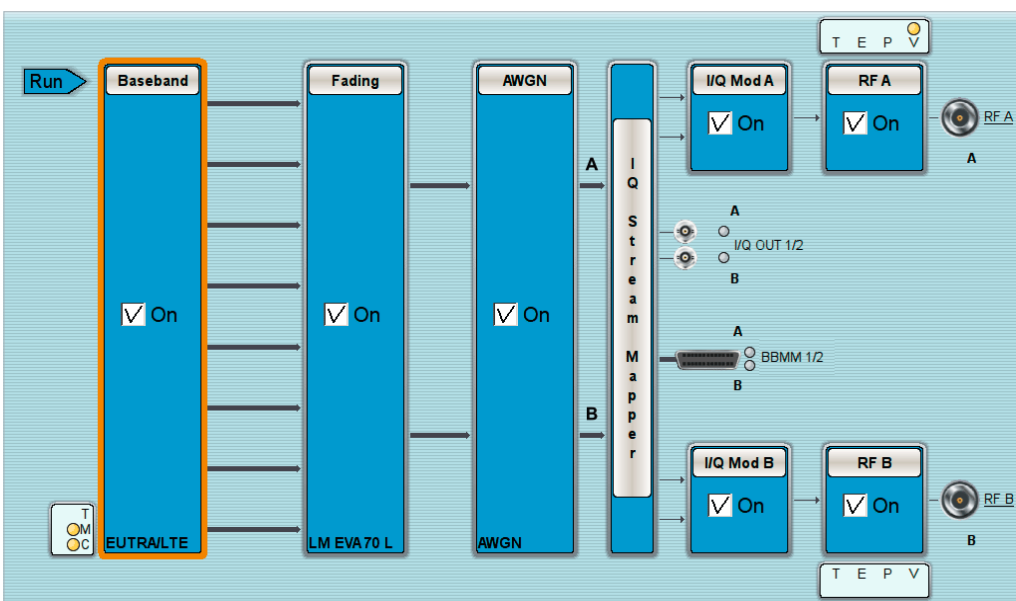

Configuration example 3:  
A fully equipped R&S®SMW200A with MIMO option covers all key MIMO scenarios, such as 8x2 shown in the screenshot. In this case, the baseband section provides eight signal sources and 16 “logical” faders, i.e. MIMO channels.

# Simplify your setup

## Easy generation of complex signals

A vector signal generator needs a powerful baseband section to meet the requirements of advanced communications systems. The R&S®SMW200A sets standards in this field too. Each of the two available baseband modules contains a realtime coder and an arbitrary waveform generator with max. 1 Gsample memory depth. The bandwidth of up to 160 MHz covers modern digital standards, such as LTE-Advanced and WLAN IEEE 802.11ac, as well as wideband multicarrier or multistandard radio signals.

The baseband signals can be digitally added, provided with a frequency offset of max.  $\pm 80$  MHz and varied in power and phase relative to each other. This makes it incredibly simple to generate multicarrier scenarios and combinations of different digital standards with the R&S®SMW200A.

A single two-path R&S®SMW200A is all that is needed to create the wanted signal plus interferer scenarios often required in receiver testing. Depending on the scenario's overall bandwidth and the desired level difference between wanted signal and interferer, the signals can in many cases be output by using only one RF path. The second RF path is available for other tasks, e.g. generation of an additional CW interferer.

If one of the two RF paths is equipped with a 12.75 GHz frequency option, then only a single instrument is needed for out-of-band blocking measurements. An additional microwave signal generator is no longer required.

## Advanced multichannel signal generation

The R&S®SMW200A generator's advanced baseband architecture enables it to simulate even complex scenarios. Up to eight internal baseband sources make it easy to generate multiple signals required, for example, for LTE carrier aggregation, multicell/multi-user simulation, interference testing or multistandard radio (MSR) tests. Optional fading and noise simulation for each of the eight individual channels is also possible.

Flexible routing capabilities and internal realtime addition of the baseband signals allow a parallelized testing approach. All signals are generated with their own periodicity. This allows the simultaneous generation of multiple carriers with nontruncated data sequences and enables a DUT to perform demodulation tests for each of the signals at the same time. As a result, the overall test time is reduced and only a minimum of hardware investment is needed.

## Two-path R&S®SMW200A

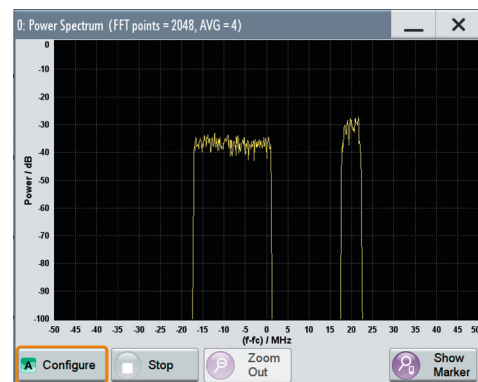
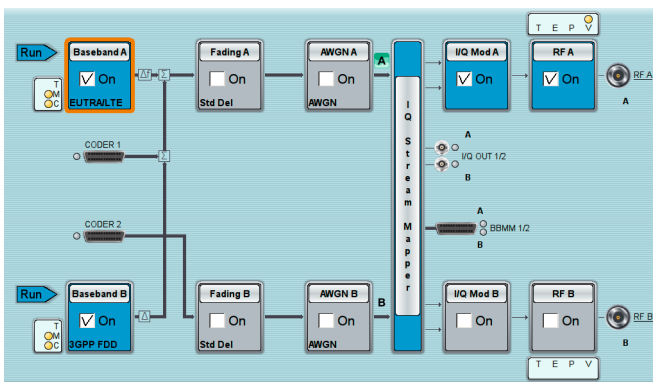

In a two-path R&S®SMW200A, baseband signals can be digitally added and provided with baseband frequency offset. This makes it possible to easily generate multicarrier scenarios or wanted signal plus interferer scenarios.

## Support of all important digital standards

The R&S®SMW200A uses software options to generate signals for all important digital standards, particularly LTE/LTE-Advanced (up to Release 11), 3GPP FDD/HSPA/HSPA+, GSM/EDGE/EDGE Evolution, TD-SCDMA and WLAN IEEE802.11a/b/g/n/j/p/ac. The entire physical layer is simulated, as well as channel coding for the majority of standards. As a result, the R&S®SMW200A is perfect for standard-compliant receiver measurements, e.g. tests on base stations in line with 3GPP TS25.141 (for 3GPP FDD) or 3GPP TS36.141 (for LTE/LTE-Advanced).

In contrast to many other solutions on the market, the signals for the digital standards can be configured and generated directly on the R&S®SMW200A. Because the software options integrate seamlessly into the instrument's firmware, there is no need for additional PC software. This simplifies operation and also saves valuable testing time, since no time-consuming waveform transfer from the external PC software to the signal generator's output memory has to be performed.

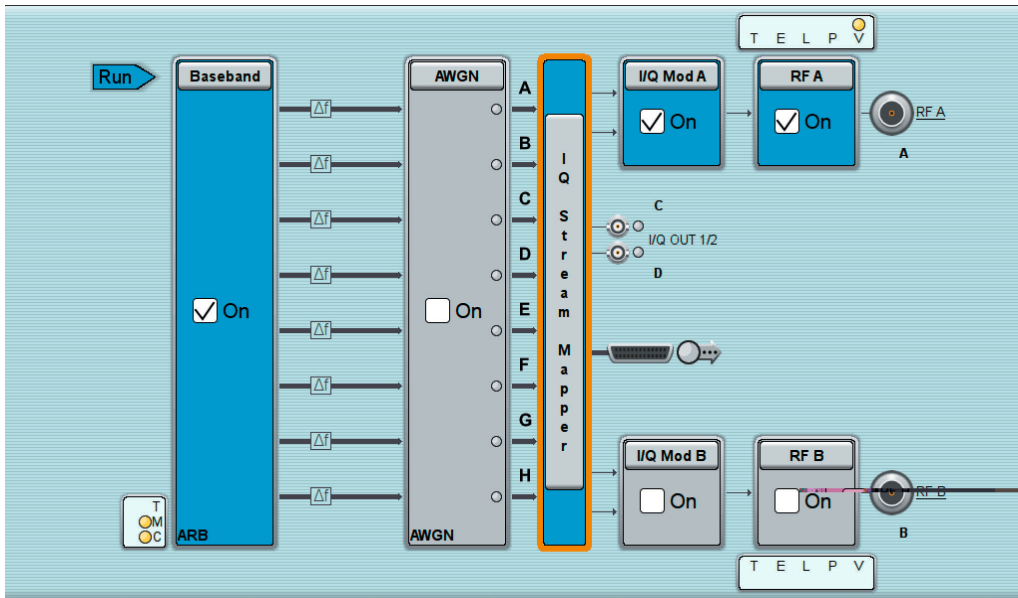

The R&S®SMW200A is the ideal generator for multistandard radio and interference tests. In this example, it is generating eight different frequency-spaced signals that are added up in realtime for receiver testing.

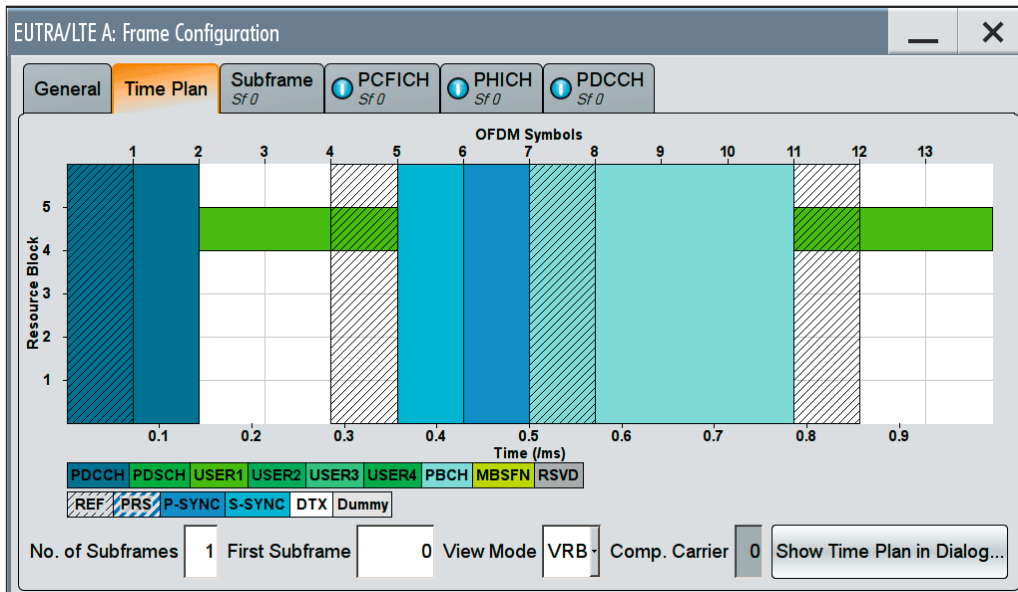

Time plan display in the LTE option of the R&S®SMW200A.

As a result of its outstanding performance, the R&S®SMW200A responds virtually without delay to new settings, even when they require comprehensive signal calculations. Therefore, test scenarios can easily and quickly be adapted to new requirements. Parameters can be varied with immediate effect for optimization or troubleshooting, without causing unproductive interruptions or waiting time.

Users benefit from numerous help functions. Predefined settings can be used to configure standard-compliant signals (e.g. test models defined in the standard) at the press of a button.

Visual aids such as the time plan in the LTE option provide a graphical overview of the signal structure. They help users keep track of even complex signal scenarios and quickly set the desired parameters.

The test case wizards for complex digital standards such as LTE and 3GPP FDD (UMTS) are powerful tools that simplify the user's task. It only takes a few steps to configure the R&S®SMW200A for base station tests in line with 3GPP TS36.141 or 3GPP TS25.141.

In many cases, conclusive measurements are only possible with correctly timed signals. This is why it is crucial for most measuring applications to synchronize measuring instruments and DUT using, for example, a frame trigger. The R&S®SMW200A meets virtually all requirements.

Internal triggering between the different baseband modules ensures internal signal generation with 100% synchronicity. Complicated cabling of multiple instruments is no longer necessary. For synchronization with the DUT the R&S®SMW200A has three front panel BNC connectors that can be assigned user-specific control signals as desired. This gives users easy access to any trigger, marker and clock signals they require.

The rear panel of the R&S®SMW200A offers another three connectors for user-specific signals and three connectors per baseband module for additional control signals.

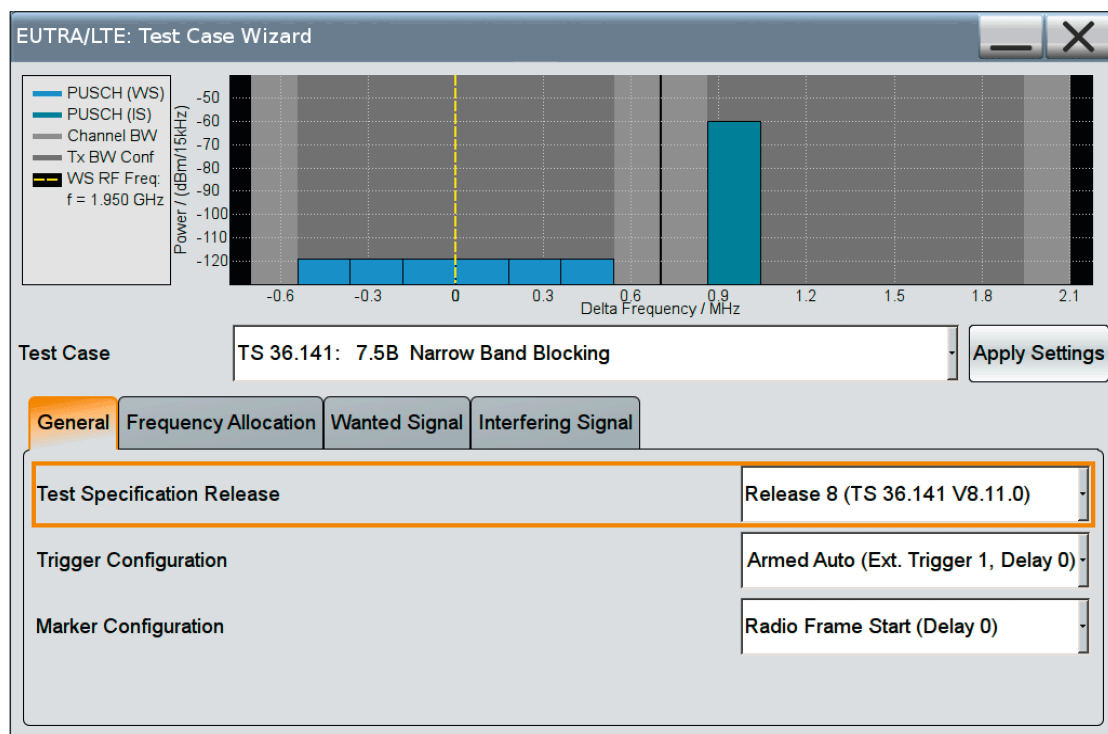

The LTE test case wizard allows the R&S®SMW200A to be conveniently and cleverly configured for BTS tests in line with 3GPP TS36.141. In this example, wanted signal and interferer for a narrowband blocking test are set.



## Efficient testing of amplifiers with envelope tracking

The objective of envelope tracking (ET) is to reduce power consumption and the amplifier's overall energy consumption. Instead of receiving a constant supply voltage, the amplifier is fed a voltage from a DC modulator. This voltage tracks the envelope of the RF signal. Extremely precise synchronization is crucial since even deviations in the nanosecond range would cause significant modulation errors (EVM).

The R&S®SMW200A offers options that allow users to very easily generate the right envelope signal for an RF signal in realtime and output it at the analog I/Q output. Since both signals come from the same instrument, users do not need to worry about synchronization. The delay between the RF signal and the envelope signal relative to each other can be set in realtime with a 1 ps resolution in order to compensate for different delays in the test setup. The digital predistortion option enables AM/AM and AM/φM predistortion of the signals in realtime. This flexibility and its outstanding signal performance make the R&S®SMW200A the perfect signal source for precise and efficient ET measurements.

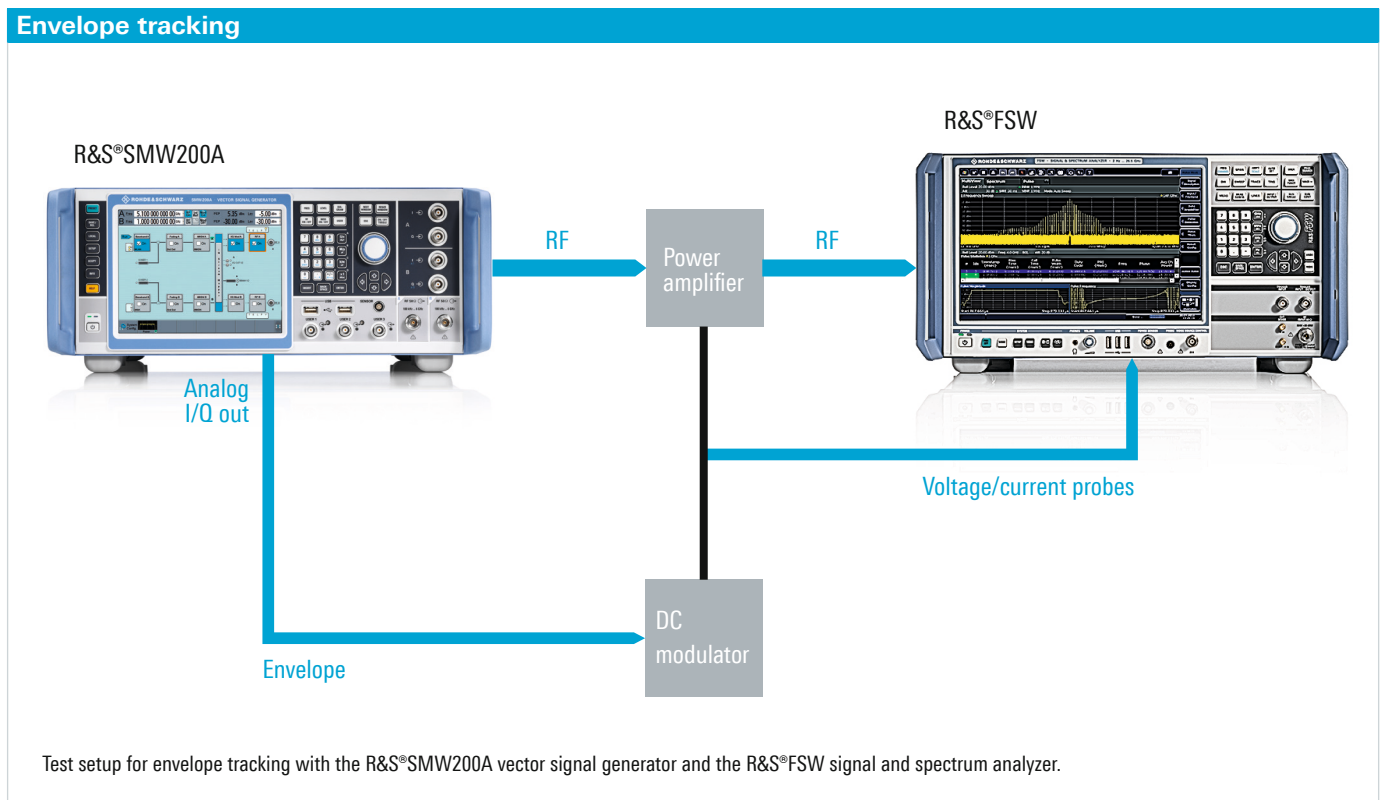

# Bring reality to your lab

## Advanced, state-of-the-art channel emulation

The internal fading simulator option is another element that distinguishes the R&S®SMW200A from other RF vector signal generators. Using latest FPGA technology the hardware was designed for exceptional compactness so that up to four of the powerful fading modules can be installed. These modules can simultaneously emulate as many as 16 fading channels. The maximum fading bandwidth is 160 MHz. As a result, the R&S®SMW200A can realistically map even MIMO scenarios such as 3x3 MIMO for WLAN IEEE 802.11.

Inside buildings, there are more reflections than in open terrain. The time difference between different echos normally is in the range of only a few nanoseconds. Its time resolution of 2.5 ps and its ability to simulate up to 20 paths per fading channels enable the R&S®SMW200A to realistically simulate indoor fading scenarios. All in all, the R&S®SMW200A offers a fading performance that has so far only been achieved by significantly more expensive special instruments (e.g. RF faders).

The user can select the fading scenarios required for all major standards directly from the predefined settings. In addition to classic multipath scenarios with Rayleigh, Rice or pure Doppler fading, the R&S®SMW200A can also simulate the dynamic scenarios specified in recent

standards, such as birth-death, moving propagation and high-speed train. All parameters can also be set manually, which makes it easy to implement user-specific fading configurations.

## Prestigious discipline: MIMO

All modern wireless communications standards utilize MIMO technology to increase the effective data throughput. A test generator must be able to simulate MIMO scenarios exactly as they are present at the receive antennas of a receiver – even with complex MIMO receivers. This is where the multipath and fading capabilities of the R&S®SMW200A come into their own. The built-in baseband modules allow the simultaneous generation of up to eight signals. For MIMO scenarios, the signals from all transmit antennas – with antenna-specific coding – can be directly generated in a single instrument.

In addition, the R&S®SMW200A is able to simulate the entire MIMO channel. Up to 16 logical faders cover all key MIMO scenarios such as 3x3, 4x4, 8x2 and 2x8. The user can also set the correlations between the propagation paths. Multistandard setups, such as simultaneous 2x2 MIMO for LTE and 3GPP FDD HSPA, are possible as well. Furthermore, carrier aggregation scenarios with four LTE component carriers (each with 2x2 MIMO) can be simulated with a single instrument. No matter how complicated the application – the R&S®SMW200A handles unique stimulus generation and channel simulation in parallel.

The R&S®SMW200A can be equipped with one or two internal RF paths. If necessary, more RF paths can be added: Two additional I/Q-modulated R&S®SGT100A signal generator modules turn the R&S®SMW200A into an extremely

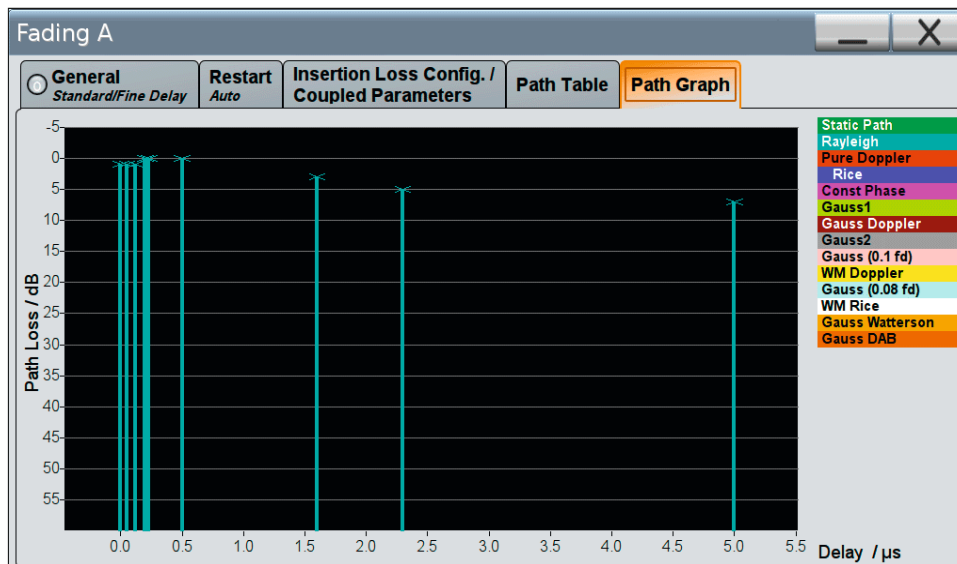

The fading settings of the R&S®SMW200A can be visualized to support the user. The screenshot shows the fading path configuration of an LTE ETU300 scenario.

compact 4x4 MIMO complete solution. Adding another four R&S®SGT100A modules enhances the solution to cover even 2x8 or 2x2x4 MIMO scenarios. The additional hardware is operated and remotely controlled directly from the R&S®SMW200A.

The R&S®SMW200A easily handles even complex MIMO setups. The global system configuration dialog can be used to reconfigure the signal generator according to the required signal scenario. The block diagram on the GUI changes with the application so that the user can see at a glance which signal scenario is being generated. Every system configuration is accompanied by typical application examples. Users who “think beyond the standard” will also easily find an optimal scenario for their needs.

In the case of MIMO-capable standards such as LTE or WLAN, the transmit signals depend on each other. Therefore, the R&S®SMW200A features a shared menu (coupled sources mode) with which multi-antenna signals can be configured quickly and conveniently.

As an alternative, the signals can be set individually in the R&S®SMW200A (separate sources mode). This mode allows the simultaneous generation of signals for different standards, which makes the R&S®SMW200A ideal for testing multistandard base stations. Combinations (e.g. LTE, WCDMA and GSM) are possible as well as the use of user-defined ARB signals.

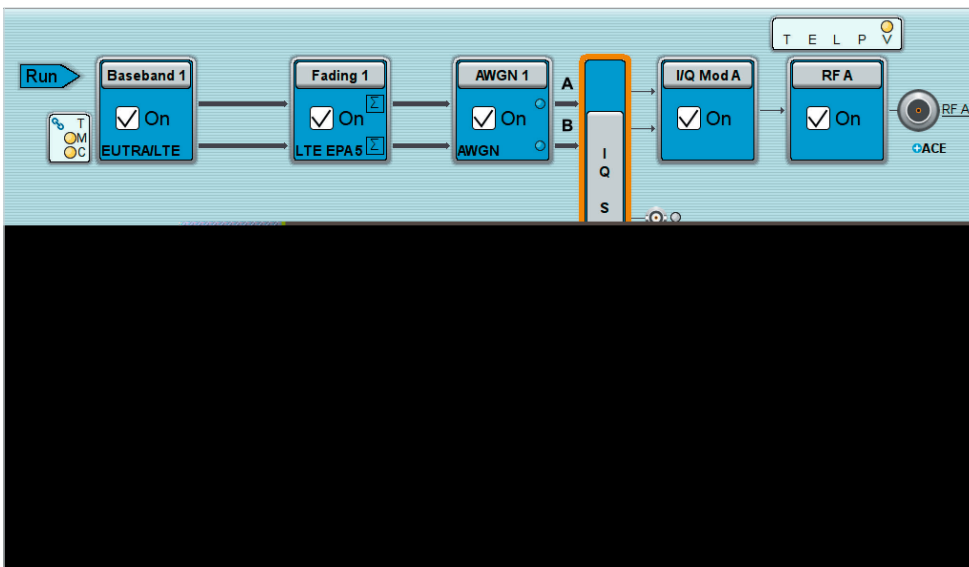

Block diagram of the R&S®SMW200A configured for the generation of a LTE Release 11 feICIC test scenario. One R&S®SMW200A simultaneously generates the LTE serving cell as well as the two aggressor cells, each with 2x2 MIMO, with correlated fading channels.

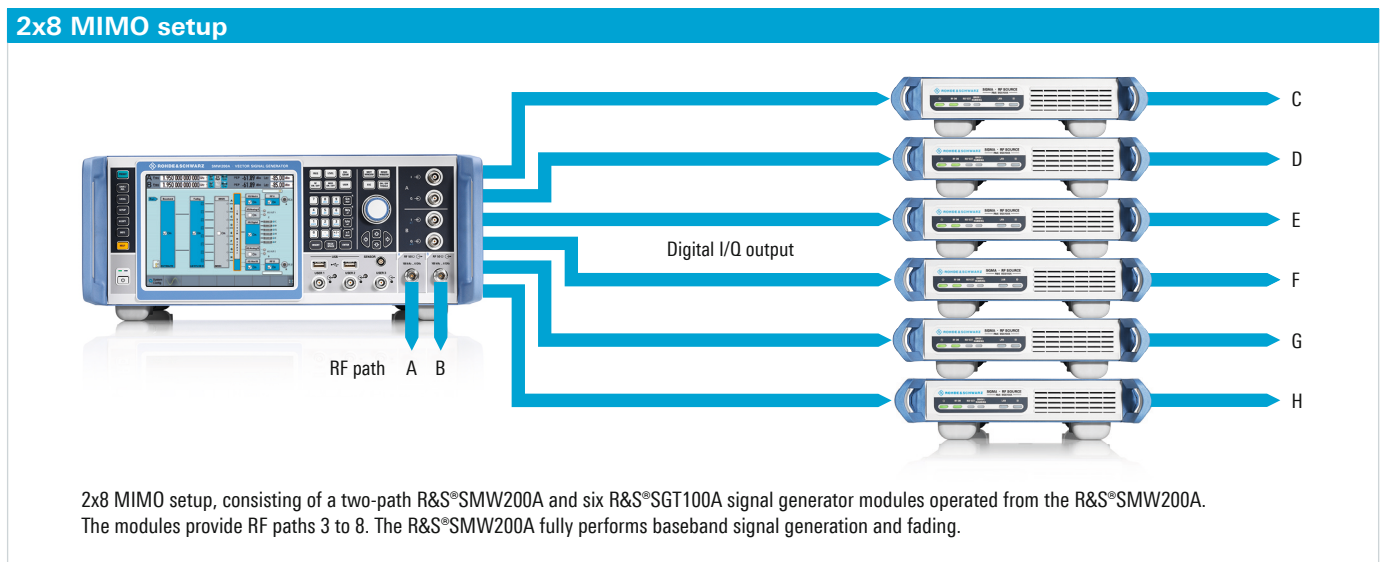

# Make your device even better

## Excellent signal quality

Testing high-performance DUTs requires a signal generator solution that features significantly better RF characteristics than the DUT itself. Otherwise, the measurement results might be falsified by the signal generator. The R&S®SMW200A fully meets this requirement, enabling the DUT's entire potential to be utilized.

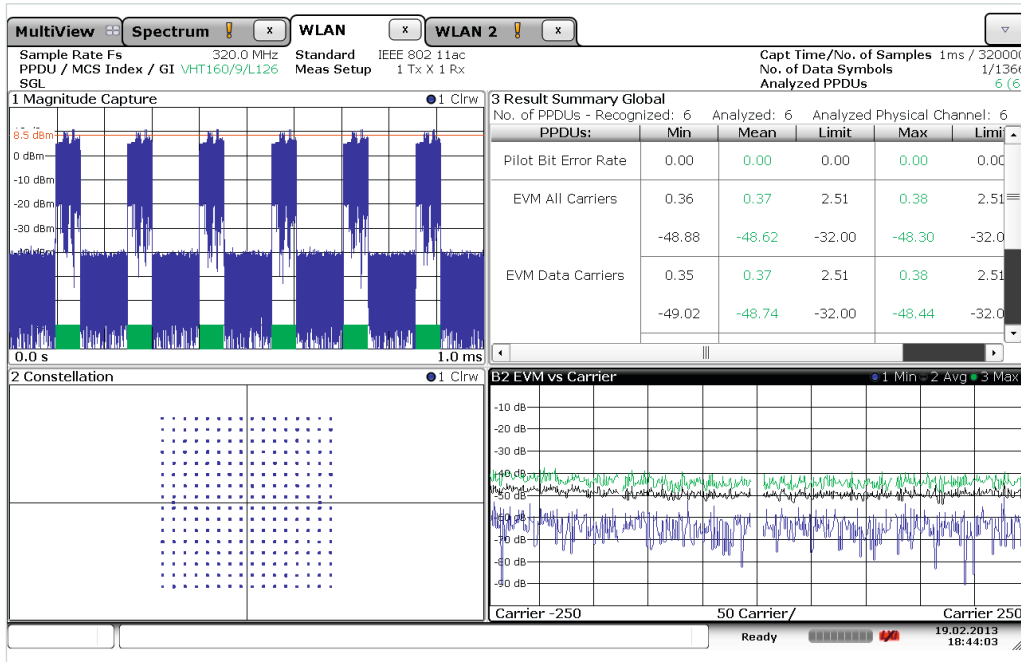

The R&S®SMW200A generates 160 MHz wide WLAN IEEE802.11ac signals with an EVM of -49 dB (meas.).

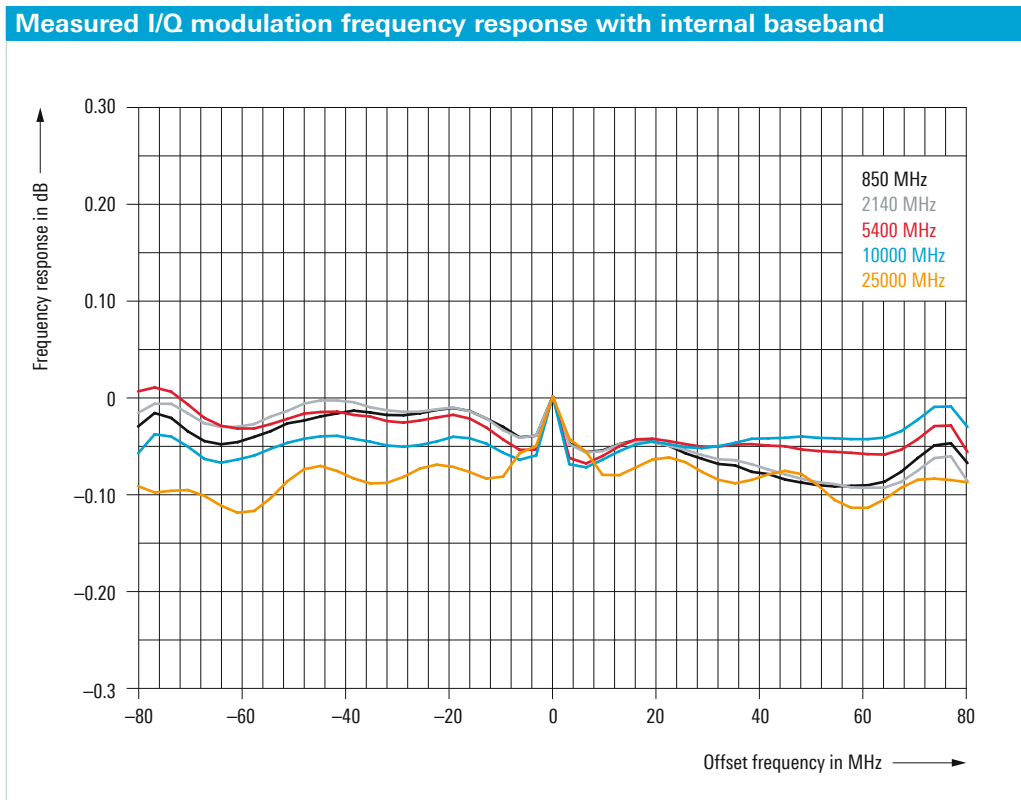

## Exceptional modulation characteristics

The R&S®SMW200A features a wideband I/Q modulator with up to 2 GHz RF bandwidth. With this bandwidth, it covers practically all applications in its frequency range, including wireless and satellite communications, radar, research and education. The internal baseband makes it possible to generate signals with a maximum width of 160 MHz. State-of-the-art 16-bit D/A converters and an excellent RF chain ensure exceptional modulation

characteristics. All in all, a modulation frequency response down to  $\pm 0.05$  dB over 160 MHz bandwidth can be achieved. The R&S®SMW200A generates 160 MHz wide WLAN IEEE802.11ac signals with an EVM of  $-49$  dB (meas.). Other signal types such as WCDMA and LTE signals, wideband QAM-modulated carriers and multicarrier CW scenarios can also be output with highest quality.

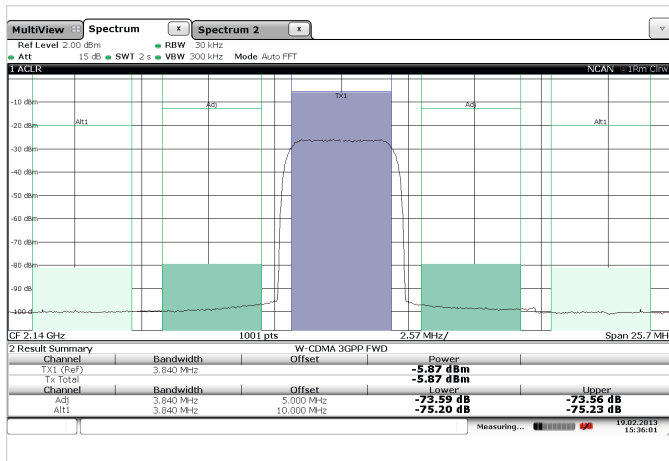

Measured ACPR for 3GPP test model 1, 64DPCH.

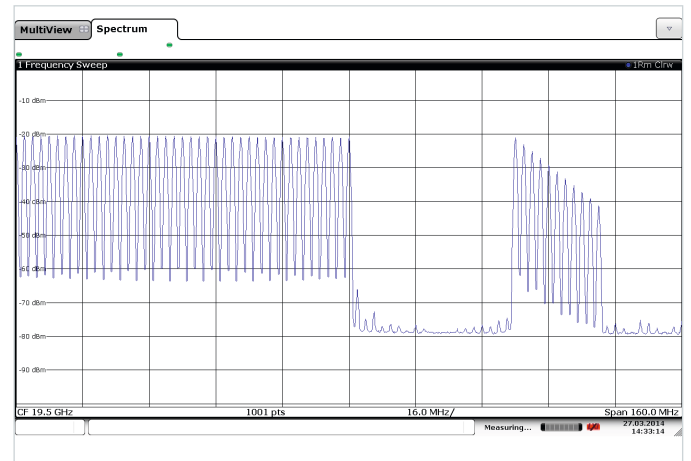

The R&S®SMW200A generates top-quality wideband signals, including signals that are asymmetrical to the center frequency. In this example, at 19.5 GHz a 160 MHz wide multicarrier CW scenario with 40 equal-power carriers is generated on the left and 10 carriers with graduated power on the right.

## Measured EVM versus carrier frequency for 16QAM

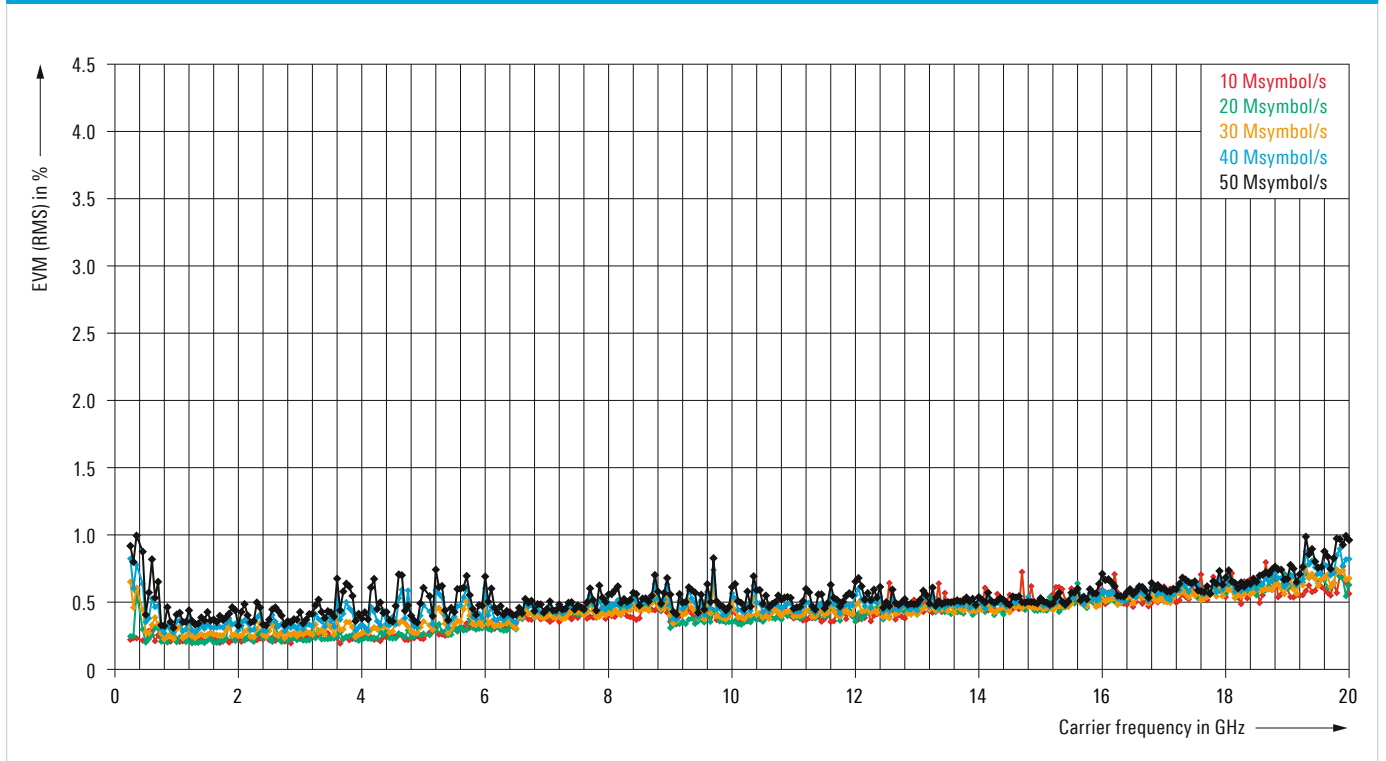

### Very good RF characteristics

The RF characteristics of the R&S®SMW200A are simply impressive. The absolute level accuracy is better than 0.5 dB ( $f \leq 3$  GHz) across the entire specified level range from -120 dBm to +18 dBm, without additional options being required. Frequency and level setting times of 600  $\mu$ s (typ.) via IEC/IEEE bus make the R&S®SMW200A the fastest high-end vector signal generator on the market and help save valuable time. Thanks to its excellent

pulse modulator with on/off ratio > 80 dB and rise/fall time < 10 ns, the R&S®SMW200A is ideal for generating pulsed signals for radar applications.

The high-end synthesizer, which is included in the standard version of the R&S®SMW200A, already delivers exceptional SSB phase noise and nonharmonics values. The R&S®SMW-B22 option improves performance even more. The R&S®SMW200A is therefore perfect for measurements that place high requirements on spectral purity.

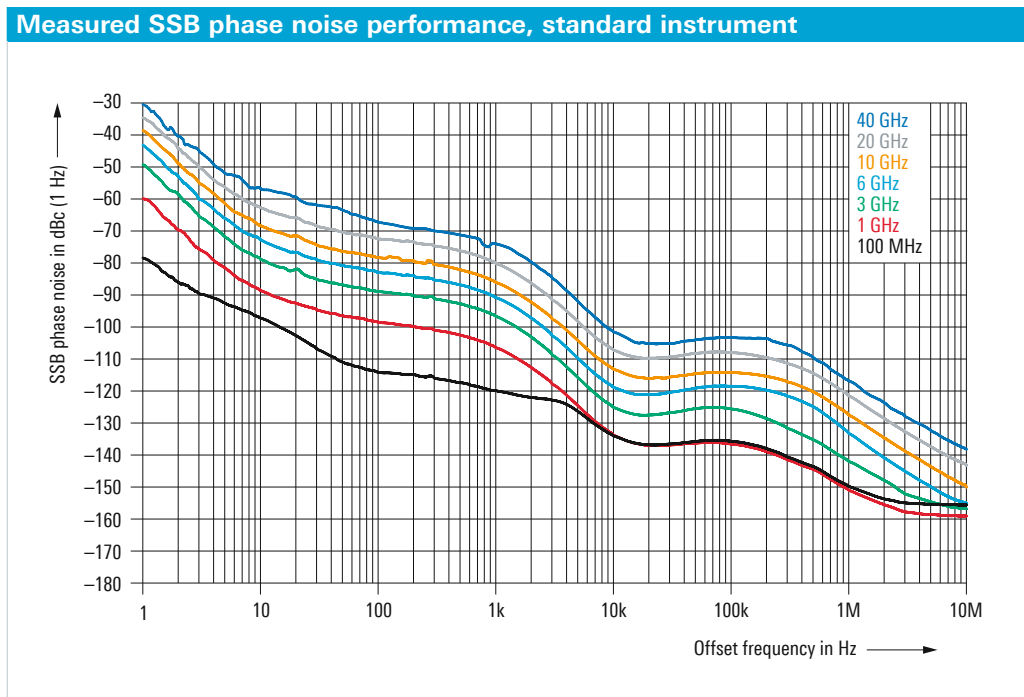
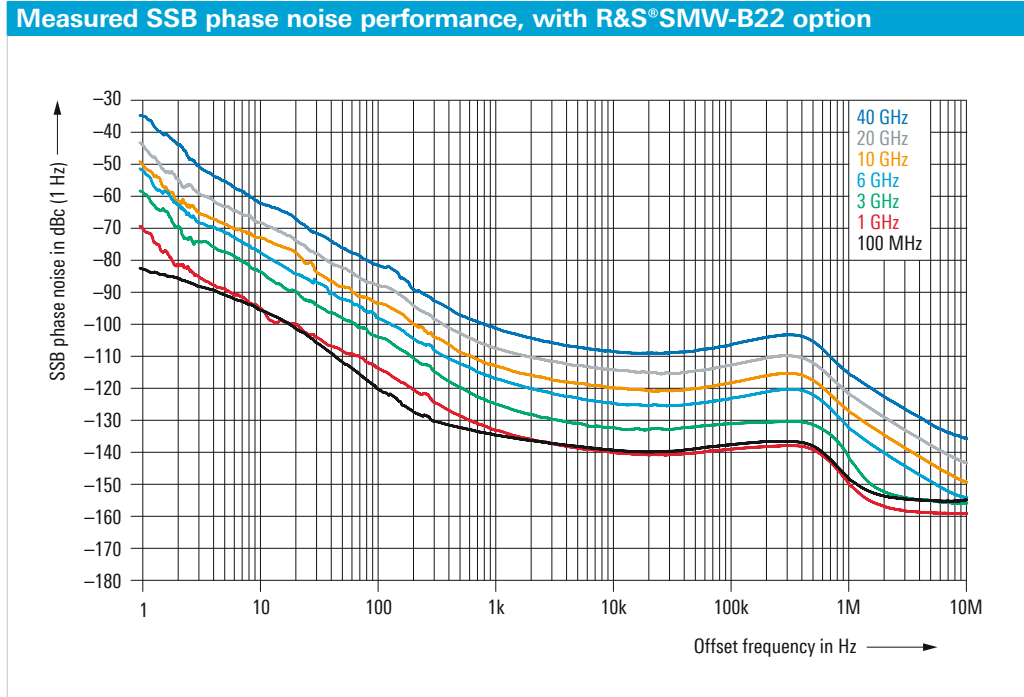

## Phase-coherent signals up to 40 GHz

Beamforming applications, such as for measurements on active antenna systems, require high-quality, phase-coherent test signals.

More than just a common reference signal is usually needed to make sure that the relative phases remain stable over a long time period. The LO coupling offered by the R&S®SMW200A enables extremely precise and stable long-term phase synchronization of both generator paths. Up to 20 GHz, the generator can provide two phase-coherent RF paths in a single instrument, without additional cabling. If more phase-coherent carriers are needed, the internal LO signal of the R&S®SMW200A can be connected to another R&S®SMW200A or an R&S®SGS100A or R&S®SGU100A signal generator module.

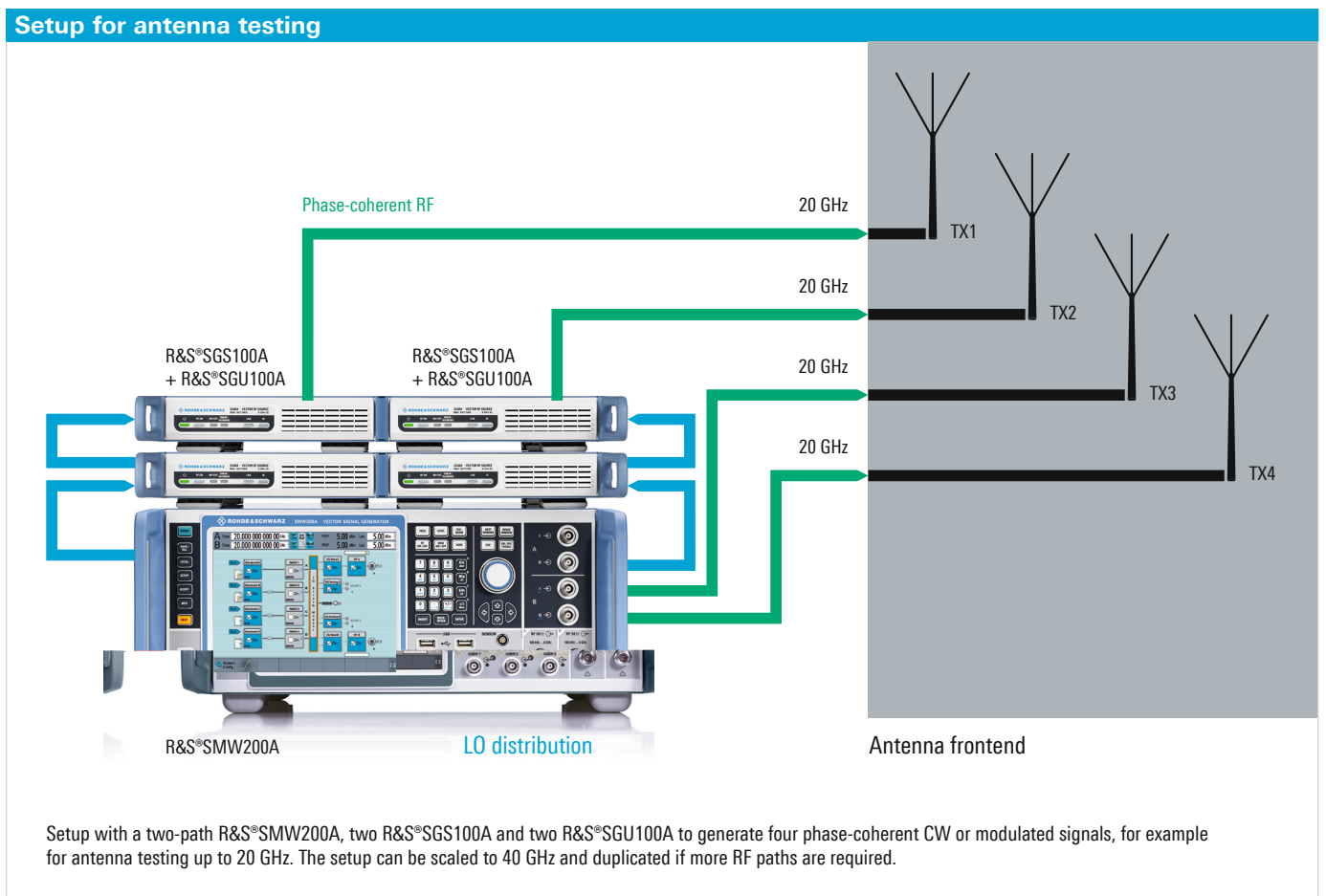

# Speed up your development

Increasing cost pressure results in ever shorter development cycles. At the same time, testing requirements are becoming more stringent. The R&S®SMW200A accomplishes complex measurement tasks quickly and efficiently. Numerous innovations in intuitive user guidance make work extremely easy.

## Ergonomic design for maximum operating convenience

A high-resolution touchscreen and an easy-to-use graphical user interface make for ergonomic operation. A block diagram provides a clear overview at all times. The user sees at a glance the signal flow and the status of all inputs and outputs. The drag&drop functionality makes signal flow reconfiguration simpler than ever. For MIMO and other complex applications, the block diagram is adapted to the prevailing signal scenario.

All menu feature tabs for fast access to signal parameters. A context-sensitive online help system provides information about every parameter, such as setting range, detailed circuit description and SCPI command. Various functions facilitate everyday work, e.g. each parameter can be individually reset to its specific preset status.

The built-in graphics function of the R&S®SMW200A allows the generated signals to be displayed in realtime in up to eight simultaneous windows. The user can select the type of display (I and Q versus time, frequency spectrum,

vector diagram, etc.) and the point in the signal flow where the measurement will be performed.

The baseband measurement function allows realtime measurement of the level of a signal or signal component at defined points in the signal flow. This feature is especially useful when the level of specific components of a complex signal is to be determined or varied during a measurement, as for example in closed-loop scenarios.

## Automation made easy

The R&S®SMW200A can be controlled via all common remote interfaces. The user benefits from a number of help functions when programming an automatic test sequence control. The SCPI commands for every setting parameter can be displayed directly and all modifications of the instrument's preset status can be highlighted graphically. This makes it easy to identify all parameters that are important for remote control.

The R&S®SMW200A also has a built-in SCPI macro recorder with code generator, which records all manual operating steps to generate a file with a remote command sequence. Code templates are provided for directly generating executable code for MATLAB® or CVI. User-specific templates can also be used. As a result, the R&S®SMW200A contributes to minimizing the time required for test automation, saving development resources.

## A fast instrument for speedy work

The LINUX-based operating system of the R&S®SMW200A helps ensure short boot times. The high computer performance speeds up work even when settings require comprehensive signal calculation.

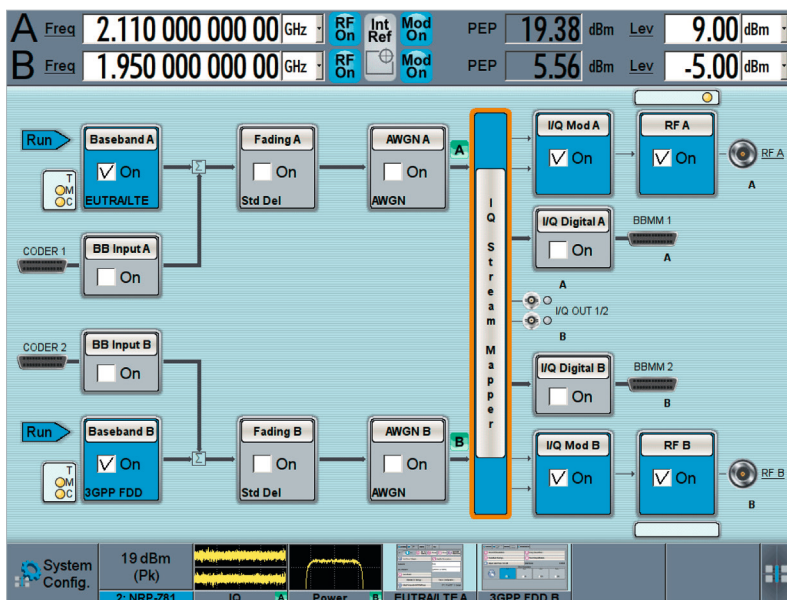

User interface of the R&S®SMW200A. The header shows the frequency, level and important instrument statuses. The footer provides quick access to open menus. The generated signals and the measurement results of any connected R&S®NRP-Zxx power sensor(s) can be displayed as well (second field from left in footer).



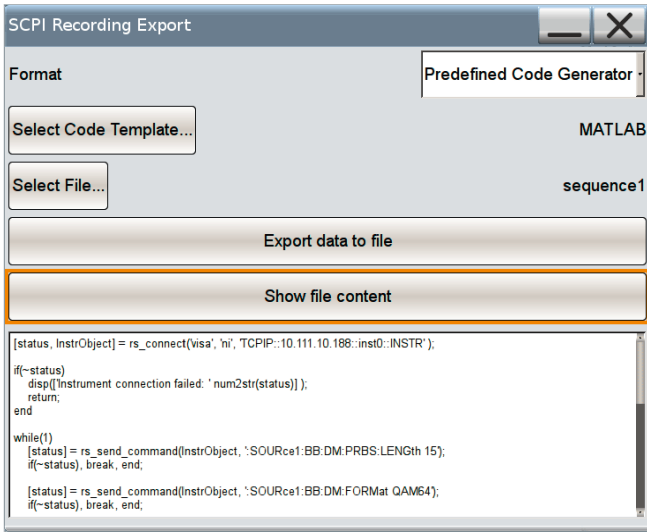

The built-in SCPI macro recorder and code generator supports fast, convenient generation of SCPI program sequences.

### Context-sensitive online help system of the R&S® SMW200A

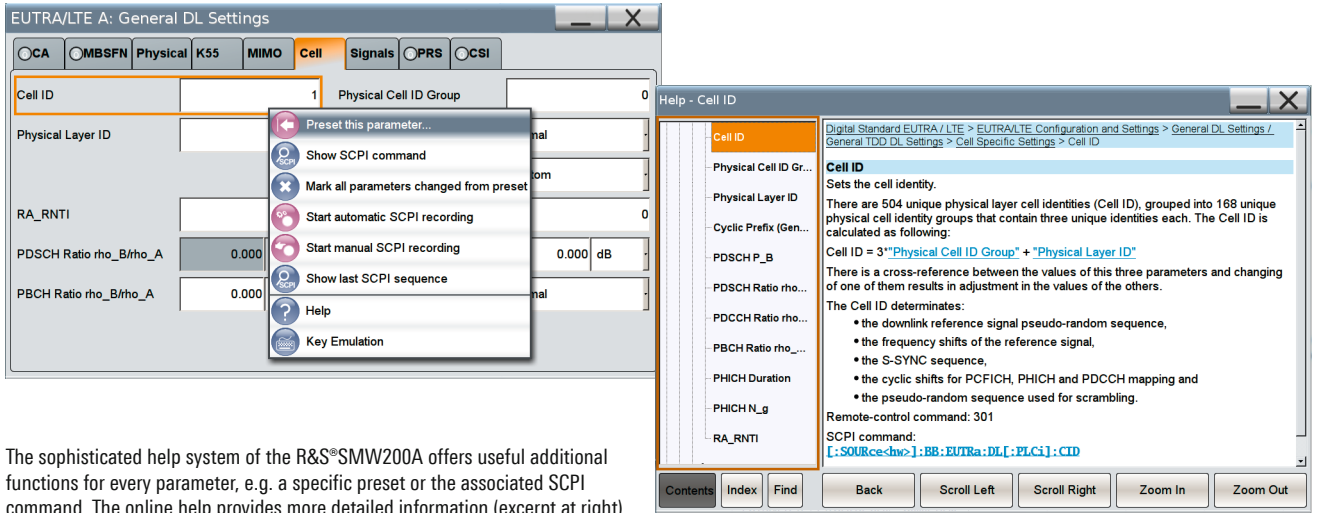

### Graphical signal monitoring in realtime

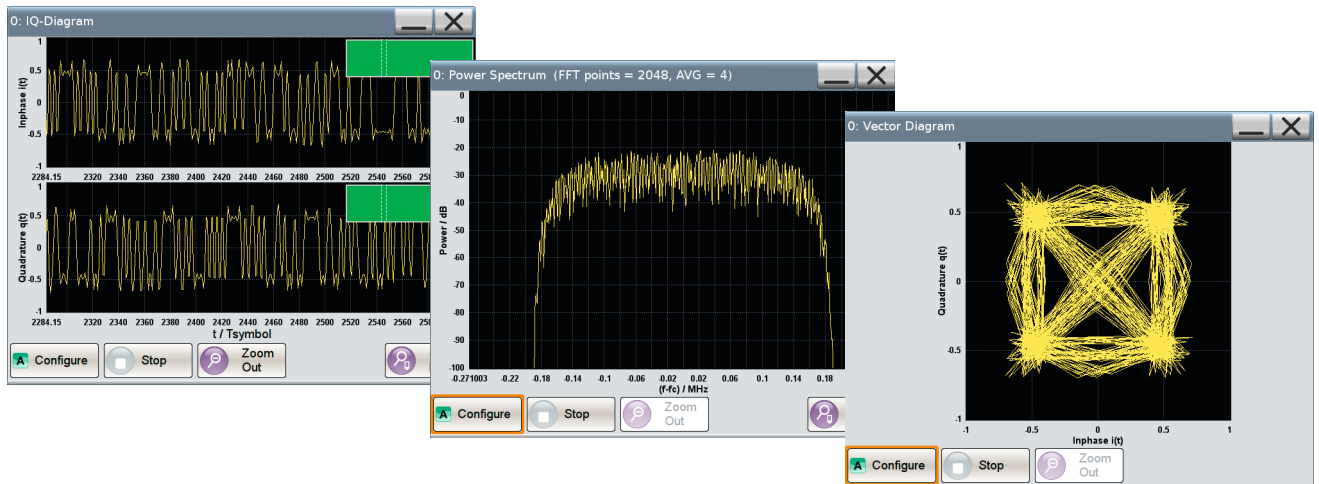

Graphical signal monitoring in realtime is extremely useful when it comes to generating complex signals.

# Grows with your needs

Advanced technology and a modular, upgradeable hardware concept make the R&S®SMW200A a future-ready investment.

R&S®SMW200A hardware options can be retrofitted with minimum effort. The baseband modules come as plug-ins and can easily be inserted into the rear panel without opening or recalibrating the instrument.

Software functions (e.g. digital standards) are simply activated via key codes. The R&S®SMW200A firmware can be updated from a USB flash drive or via LAN. Free updates can be downloaded from [www.rohde-schwarz.com/product/smw200a](http://www.rohde-schwarz.com/product/smw200a).

In this way, the R&S®SMW200A can be precisely customized to suit the applications at hand and can be enhanced whenever new requirements arise. Users only have to purchase what they currently need and are free to decide on upgrades according to future requirements.

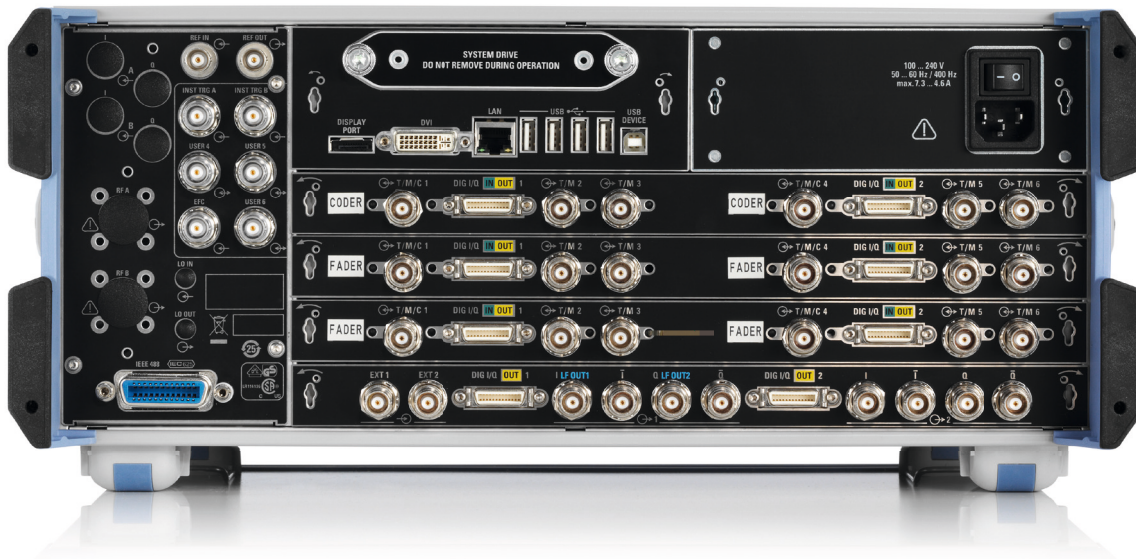

Rear panel of the R&S®SMW200A.

## The R&S®SMW200A can be used together with many other Rohde & Schwarz instruments

R&S®SMW200A function/connection	Related option(s)	Rohde & Schwarz partner instrument	Application example
Digital baseband input	R&S®SMW-B10	e.g. R&S®CMW500 wideband radio communication tester	R&S®CMW500 as external I/Q source, e.g. for signaling <sup>1)</sup>
Digital baseband output	R&S®SMW-K18	e.g. R&S®EX-IQ-Box digital signal interface module	outputs digital baseband signals in different formats, e.g. in line with the CPRI standard
Analog I/Q output	R&S®SMW-K16	e.g. R&S®SGT100A signal generator module e.g. R&S®SGS100A signal generator module	provides additional RF paths
R&S®NRP sensor connector	–	R&S®NRP-Zxx power sensors, R&S®NRP-Z28/-Z98 level control sensors	high-accuracy power measurement, result display on the R&S®SMW200A

<sup>1)</sup> Function in preparation.

# Specifications in brief

Specifications in brief		
<b>Frequency</b>		
Frequency range, RF path A	R&S®SMW-B103	100 kHz to 3 GHz
	R&S®SMW-B106	100 kHz to 6 GHz
	R&S®SMW-B112	100 kHz to 12.75 GHz
	R&S®SMW-B120	100 kHz to 20 GHz
	R&S®SMW-B131	100 kHz to 31.8 GHz
	R&S®SMW-B140	100 kHz to 40 GHz
Frequency range, RF path B (optional, see R&S®SMW200A data sheet for possible RF path configurations)	R&S®SMW-B203	100 kHz to 3 GHz
	R&S®SMW-B206	100 kHz to 6 GHz
	R&S®SMW-B212	100 kHz to 12.75 GHz
	R&S®SMW-B220	100 kHz to 20 GHz
Setting time	SCPI mode, $f < 6$ GHz	< 1.2 ms, 600 $\mu$ s (typ.)
<b>Level</b>		
Specified level range	$3 \text{ MHz} \leq f \leq 20 \text{ GHz}$	-120 dBm to +18 dBm (PEP)
	R&S®SMW-B131, R&S®SMW-B140	-120 dBm to +15/+18 dBm (PEP), depending on RF
Setting time	SCPI mode	< 1 ms, 600 $\mu$ s (typ.)
	R&S®SMW-B120/-B131/-B140/-B220, with switching of mechanical step attenuator	< 25 ms
<b>Spectral purity</b>		
Harmonics	level < 10 dBm, CW	< -30 dBc
	R&S®SMW-B120/-B131/-B140/-B220, $f > 3.5$ GHz	< -55 dBc
Nonharmonics	CW or vector modulation with full-scale DC input, $200 \text{ MHz} < f \leq 1500 \text{ MHz}$	level > -10 dBm, carrier offset > 10 kHz
	standard	< -80 dBc
	with R&S®SMW-B22 option	< -90 dBc
SSB phase noise	CW, carrier offset = 20 kHz, $f = 1$ GHz	
	standard	< -131 dBc, -135 dBc (typ.)
	with R&S®SMW-B22 option	< -136 dBc, -139 dBc (typ.)
	CW, carrier offset = 20 kHz, $f = 10$ GHz	
	standard	< -111 dBc, -115 dBc (typ.)
	with R&S®SMW-B22 option	< -116 dBc, -119 dBc (typ.)
<b>Analog modulation</b>		
Supported analog modulation modes		AM, FM (optional), $\phi$ M (optional), pulse (optional)
<b>I/Q modulation</b>		
RF modulation bandwidth	with external I/Q, "I/Q wideband" on	
	$1 \text{ MHz} \leq f \leq 4 \text{ GHz}$	$\pm 25\%$ of carrier frequency
	$f > 4 \text{ GHz}$	$\pm 1$ GHz
	with internal baseband, "I/Q wideband" on, $f \geq 320 \text{ MHz}$	$\pm 80 \text{ MHz}$
Modulation frequency response in specified RF modulation bandwidth	with internal baseband, "I/Q wideband" on	< 1.0 dB, < 0.3 dB (meas.)
<b>Baseband generator</b>		
	R&S®SMW-B10 option, up to two baseband generators can be installed	
Signal bandwidth	standard	120 MHz
	with R&S®SMW-K522 option	160 MHz
ARB memory depth	standard	64 Msample
	with R&S®SMW-K511 option	512 Msample
	with R&S®SMW-K511 and -K512 options	1 Gsample
Sample resolution	equivalent to D/A converter	16 bit
Frequency offset	standard	-60 MHz to +60 MHz
	with R&S®SMW-K522 option	-80 MHz to +80 MHz

## Specifications in brief (cont.)

### Digital standards

Supported standards and modulation systems	LTE Release 8/9/10/11, 3GPP FDD/HSPA/HSPA+, GSM/EDGE/EDGE Evolution, CDMA2000®, 1xEV-DO Rev. A/B, TD-SCDMA, WLAN IEEE 802.11a/b/g/n/j/p/ac, AWGN and more
--	---

### Fading and MIMO

Fading simulator	R&S®SMW-B14 option, up to four fading modules can be installed	
Fading bandwidth		max. 160 MHz
Fading channels	depending on options	max. 16
MIMO fading scenarios	depending on options	2x2, 4x2, 2x4, 3x3, 4x4, 8x2, 2x8, 2x2x2, 2x4x2, 2x2x4, 4x2x2 and more
Fading modes	depending on options	multipath, moving delay, birth-death, high-speed train, two-channel interferer
Fading profiles	depending on options	Rayleigh, Rice, pure Doppler, static path, Gaussian, customized and more

## Options for digital communications standards (selection)

Standard/technology	Options	Key features
LTE/LTE-Advanced	R&S®SMW-K55/-K69/-K81/-K84/-K85/-K112	<ul style="list-style-type: none"> <li>▀ In line with 3GPP LTE Release 8, 9, 10, 11</li> <li>▀ FDD and TDD</li> <li>▀ Downlink (OFDMA) and uplink (SC-FDMA)</li> <li>▀ Carrier aggregation</li> <li>▀ Support of uplink closed-loop base station tests in line with 3GPP TS 36.141</li> <li>▀ LTE test case wizard</li> </ul>
3GPP FDD/HSPA/HSPA+	R&S®SMW-K42/-K83	<ul style="list-style-type: none"> <li>▀ In line with 3GPP FDD Release 11</li> <li>▀ Downlink and uplink</li> <li>▀ HSDPA H-sets</li> <li>▀ Higher-order modulation, MIMO, CPC</li> <li>▀ Support of base station tests in line with 3GPP TS 25.141</li> <li>▀ 3GPP test case wizard</li> </ul>
GSM/EDGE/EDGE Evolution	R&S®SMW-K40/-K41	<ul style="list-style-type: none"> <li>▀ MSK, FSK, AQPSK, 8PSK, 16QAM and 32QAM modulation</li> <li>▀ Mixed frames with GSM, EDGE and EGPRS2 slots</li> <li>▀ VAMOS support</li> <li>▀ Support of higher symbol rates (325 kHz)</li> <li>▀ "Framed double" sequence mode for generating realistic test scenarios with changing frame content</li> </ul>
CDMA2000®	R&S®SMW-K46	<ul style="list-style-type: none"> <li>▀ In line with 3GPP2 C.S0002-C</li> <li>▀ Radio configurations RC1 to RC5 and RC10 in forward link, RC1 to RC4 in reverse link</li> <li>▀ All channel coding modes included in IS-2000</li> </ul>
1xEV-DO Rev. A, B	R&S®SMW-K47/-K87	<ul style="list-style-type: none"> <li>▀ Forward link and reverse link</li> <li>▀ Physical layer subtypes 0 &amp; 1, 2 or 3</li> <li>▀ Multicarrier scenarios with up to 16 concurrent channels</li> </ul>
TD-SCDMA (3GPP TDD LCR)	R&S®SMW-K50/-K51	<ul style="list-style-type: none"> <li>▀ Simulation of up to four TD-SCDMA cells with variable uplink and downlink switching point</li> <li>▀ Fixed reference measurement channels up to RMC 384 kbps in uplink and downlink</li> <li>▀ HSDPA and HSUPA channels</li> </ul>
WLAN IEEE 802.11a/b/g/n/j/p/ac	R&S®SMW-K54/-K86	<ul style="list-style-type: none"> <li>▀ Support of all mandatory physical layer modes</li> <li>▀ VHT frames with up to 160 MHz transmission bandwidth</li> <li>▀ BPSK, QPSK, 16QAM and 256QAM modulation</li> <li>▀ MIMO modes with four transmit antennas</li> <li>▀ Frame block sequencer for alternating legacy frames in line with 11a/b/g/j/p, 11n or 11ac</li> </ul>
WiMAX™ IEEE 802.16	R&S®SMW-K49	<ul style="list-style-type: none"> <li>▀ OFDM and OFDMA modulation</li> <li>▀ Multiple zones and segments</li> <li>▀ Space time coding for up to four antennas</li> </ul>
Bluetooth®	R&S®SMW-K60	<ul style="list-style-type: none"> <li>▀ Bluetooth® 4.0, basic rate + EDR</li> <li>▀ Bluetooth® low energy</li> <li>▀ Support of all packet types</li> <li>▀ Dirty transmitter</li> </ul>

For more information, see R&S®SMW200A data sheet (PD 3606.8037.22), R&S®SMW200A configuration guide (PD 3606.8037.92), "Digital Standards for Signal Generators" data sheet (PD 5213.9434.22) and [www.rohde-schwarz.com/product/smw200a](http://www.rohde-schwarz.com/product/smw200a).

# Ordering information

Designation	Type	Order No.
<b>Vector Signal Generator<sup>1)</sup></b> including power cable, quick start guide and CD-ROM (with operating and service manual)	R&S®SMW200A	1412.0000.02
<b>Options</b>		
R&S®SMW-Bxxx = hardware option		
R&S®SMW-Kxxx = software/key code option		
Frequency options, RF path A		
100 kHz to 3 GHz	R&S®SMW-B103	1413.0004.02
100 kHz to 6 GHz	R&S®SMW-B106	1413.0104.02
100 kHz to 12.75 GHz	R&S®SMW-B112	1413.0204.03
100 kHz to 20 GHz	R&S®SMW-B120	1413.0404.02
100 kHz to 31.8 GHz	R&S®SMW-B131	1413.8605.02
100 kHz to 40 GHz	R&S®SMW-B140	1413.0604.02
Signal routing and baseband main modules		
Signal Routing and Baseband Main Module, one I/Q path to RF	R&S®SMW-B13	1413.2807.02
Signal Routing and Baseband Main Module, two I/Q paths to RF	R&S®SMW-B13T	1413.3003.02
Frequency options, RF path B		
100 kHz to 3 GHz	R&S®SMW-B203	1413.0804.02
100 kHz to 6 GHz	R&S®SMW-B206	1413.0904.02
100 kHz to 12.75 GHz	R&S®SMW-B212	1413.1000.03
100 kHz to 20 GHz	R&S®SMW-B220	1413.1100.02
Other RF options		
FM/φM Modulator	R&S®SMW-B20	1413.1600.02
Enhanced Phase Noise Performance and FM/φM Modulator	R&S®SMW-B22	1413.2207.02
Phase Coherence	R&S®SMW-B90	1413.5841.02
Pulse Modulator	R&S®SMW-K22	1413.3249.02
Pulse Generator	R&S®SMW-K23	1413.3284.02
Multifunction Generator	R&S®SMW-K24	1413.3332.02
Differential Analog I/Q Inputs	R&S®SMW-K739	1413.7167.02
Baseband		
Baseband Generator with ARB (64 Msample) and Digital Modulation (realtime), 120 MHz RF bandwidth	R&S®SMW-B10	1413.1200.02
Differential Analog I/Q Outputs	R&S®SMW-K16	1413.3384.02
Digital Baseband Output	R&S®SMW-K18	1413.3432.02
ARB Memory Extension to 512 Msample	R&S®SMW-K511	1413.6860.02
ARB Memory Extension to 1 Gsample	R&S®SMW-K512	1413.6919.02
Baseband Extension to 160 MHz RF bandwidth	R&S®SMW-K522	1413.6960.02
Envelope Tracking	R&S®SMW-K540	1413.7215.02
AM/AM, AM/φM Predistortion	R&S®SMW-K541	1413.7267.02
Slow I/Q	R&S®SMW-K551	1413.9724.02
Multichannel, MIMO, fading and noise		
Fading Simulator	R&S®SMW-B14	1413.1500.02
Additive White Gaussian Noise (AWGN)	R&S®SMW-K62	1413.3484.02
Dynamic Fading	R&S®SMW-K71	1413.3532.02
Enhanced Fading Models	R&S®SMW-K72	1413.3584.02
MIMO Fading/Routing	R&S®SMW-K74	1413.3632.02
Multiple Entities	R&S®SMW-K76	1413.9624.02

<sup>1)</sup> The base unit can only be ordered with an R&S®SMW-B10x frequency option and an R&S®SMW-B13 or R&S®SMW-B13T signal routing and baseband main module.

Designation	Type	Order No.
Digital standards		
GSM/EDGE	R&S®SMW-K40	1413.3684.02
EDGE Evolution	R&S®SMW-K41	1413.3732.02
3GPP FDD	R&S®SMW-K42	1413.3784.02
CDMA2000®	R&S®SMW-K46	1413.3884.02
1xEV-DO	R&S®SMW-K47	1413.3932.02
IEEE802.16	R&S®SMW-K49	1413.3984.02
TD-SCDMA	R&S®SMW-K50	1413.4039.02
TD-SCDMA Enhanced BS/MS Tests	R&S®SMW-K51	1413.4080.02
DVB-H/DVB-T	R&S®SMW-K52	1413.6090.02
IEEE802.11 (a/b/g/n)	R&S®SMW-K54	1413.4139.02
EUTRA/LTE	R&S®SMW-K55	1413.4180.02
Bluetooth® EDR	R&S®SMW-K60	1413.4239.02
Multicarrier CW Signal Generation	R&S®SMW-K61	1413.4280.02
TETRA Release 2	R&S®SMW-K68	1413.4439.02
LTE Closed-Loop BS Test	R&S®SMW-K69	1413.4480.02
LTE Log File Generation	R&S®SMW-K81	1413.4539.02
3GPP FDD HSPA/HSPA+, Enhanced BS/MS Tests	R&S®SMW-K83	1413.4580.02
EUTRA/LTE Release 9 and Enhanced Features	R&S®SMW-K84	1413.5435.02
EUTRA/LTE Release 10 (LTE-Advanced)	R&S®SMW-K85	1413.5487.02
IEEE802.11ac	R&S®SMW-K86	1413.5635.02
1xEV-DO Rev. B	R&S®SMW-K87	1413.6519.02
NFC A/B/F	R&S®SMW-K89	1413.6619.02
LTE Release 11 and Enhanced Features	R&S®SMW-K112	1413.8505.02
Baseband Power Sweep	R&S®SMW-K542	1413.9876.02
Digital standards using R&S®WinIQSIM2™ 2)		
GSM/EDGE	R&S®SMW-K240	1413.4739.02
EDGE Evolution	R&S®SMW-K241	1413.4780.02
3GPP FDD	R&S®SMW-K242	1413.4839.02
GPS 1 Satellite	R&S®SMW-K244	1413.4880.02
CDMA2000®	R&S®SMW-K246	1413.4939.02
1xEV-DO	R&S®SMW-K247	1413.4980.02
IEEE802.16	R&S®SMW-K249	1413.5035.02
TD-SCDMA	R&S®SMW-K250	1413.5087.02
TD-SCDMA Enhanced BS/MS Tests	R&S®SMW-K251	1413.5135.02
DVB-H/DVB-T	R&S®SMW-K252	1413.6190.02
DAB/T-DMB	R&S®SMW-K253	1413.6248.02
IEEE802.11n	R&S®SMW-K254	1413.5187.02
EUTRA/LTE	R&S®SMW-K255	1413.5235.02
Bluetooth® EDR	R&S®SMW-K260	1413.5287.02
Multicarrier CW Signal Generation	R&S®SMW-K261	1413.5335.02
Additive White Gaussian Noise (AWGN)	R&S®SMW-K262	1413.6460.02
Galileo 1 Satellite	R&S®SMW-K266	1413.7015.02
TETRA Release 2	R&S®SMW-K268	1413.5387.02
3GPP FDD HSPA/HSPA+, Enhanced BS/MS Tests	R&S®SMW-K283	1413.6290.02
EUTRA/LTE Release 9 and Enhanced Features	R&S®SMW-K284	1413.5535.02
EUTRA/LTE Release 10 (LTE-Advanced)	R&S®SMW-K285	1413.5587.02
IEEE802.11ac	R&S®SMW-K286	1413.5687.02
1xEV-DO Rev. B	R&S®SMW-K287	1413.6560.02
NFC A/B/F	R&S®SMW-K289	1413.6654.02
Glomass 1 Satellite	R&S®SMW-K294	1413.7067.02
Beidou 1 Satellite	R&S®SMW-K407	1413.7115.02
LTE Release 11 and Enhanced Features	R&S®SMW-K412	1413.8557.02

<sup>2)</sup> R&S®WinIQSIM2™ requires an external PC.

Designation	Type	Order No.
Other options		
Rear Panel Connectors for RF path A and I/Q, for R&S®SMW-B103 or R&S®SMW-B106 frequency option	R&S®SMW-B81	1413.5893.02
Rear Panel Connectors for RF path B, for R&S®SMW-B203 or R&S®SMW-B206 frequency option	R&S®SMW-B82	1413.5941.02
Recommended extras		
19" Rack Adapter	R&S®ZZA-KN4	1175.3033.00
Cable for connecting Rohde&Schwarz digital baseband interfaces	R&S®SMU-Z6	1415.0201.02
Keyboard with USB Interface (US assignment)	R&S®PSL-Z2	1157.6870.04
USB Serial Adapter for RS-232 remote control	R&S®TS-USB1	6124.2531.00
Adapters for instruments with an R&S®SMW-B112/-B212/-B120/-B220/-B131/-B140 frequency option		
Test Port Adapter, 2.92 mm female		1036.4790.00
Test Port Adapter, 2.92 mm male		1036.4802.00
Test Port Adapter, N female		1036.4777.00
Test Port Adapter, N male		1036.4783.00
Documentation		
Documentation of Calibration Values	R&S®DCV-2	0240.2193.18
R&S®SMW200A DAkS Calibration (ISO 17025, ISO 9000)	R&S®SMW200ADKD	1413.6690.02

Service options		
Extended Warranty, one year	R&S®WE1	Please contact your local Rohde&Schwarz sales office.
Extended Warranty, two years	R&S®WE2	
Extended Warranty, three years	R&S®WE3	
Extended Warranty, four years	R&S®WE4	
Extended Warranty with Calibration Coverage, one year	R&S®CW1	
Extended Warranty with Calibration Coverage, two years	R&S®CW2	
Extended Warranty with Calibration Coverage, three years	R&S®CW3	
Extended Warranty with Calibration Coverage, four years	R&S®CW4	

Your local Rohde&Schwarz expert will help you determine the optimum solution for your requirements. To find your nearest Rohde&Schwarz representative, visit [www.sales.rohde-schwarz.com](http://www.sales.rohde-schwarz.com)

The Bluetooth® word mark and logos are registered trademarks owned by Bluetooth SIG, Inc. and any use of such marks by Rohde&Schwarz is under license.

CDMA2000® is a registered trademark of the Telecommunications Industry Association (TIA-USA).

“WiMAX Forum” is a registered trademark of the WiMAX Forum. “WiMAX”, the WiMAX Forum logo, “WiMAX Forum Certified”, and the WiMAX Forum Certified logo are trademarks of the WiMAX Forum.

## Service that adds value

- ▮ Worldwide
- ▮ Local and personalized
- ▮ Customized and flexible
- ▮ Uncompromising quality
- ▮ Long-term dependability

## About Rohde & Schwarz

The Rohde & Schwarz electronics group is a leading supplier of solutions in the fields of test and measurement, broadcasting, secure communications, and radiomonitoring and radiolocation. Founded more than 80 years ago, this independent global company has an extensive sales network and is present in more than 70 countries. The company is headquartered in Munich, Germany.

## Sustainable product design

- ▮ Environmental compatibility and eco-footprint
- ▮ Energy efficiency and low emissions
- ▮ Longevity and optimized total cost of ownership

Certified Quality Management

ISO 9001

Certified Environmental Management

ISO 14001

## Rohde & Schwarz GmbH & Co. KG

[www.rohde-schwarz.com](http://www.rohde-schwarz.com)

## Regional contact

- ▮ Europe, Africa, Middle East | +49 89 4129 12345  
[customersupport@rohde-schwarz.com](mailto:customersupport@rohde-schwarz.com)
- ▮ North America | 1 888 TEST RSA (1 888 837 87 72)  
[customer.support@rsa.rohde-schwarz.com](mailto:customer.support@rsa.rohde-schwarz.com)
- ▮ Latin America | +1 410 910 79 88  
[customersupport.la@rohde-schwarz.com](mailto:customersupport.la@rohde-schwarz.com)
- ▮ Asia Pacific | +65 65 13 04 88  
[customersupport.asia@rohde-schwarz.com](mailto:customersupport.asia@rohde-schwarz.com)
- ▮ China | +86 800 810 82 28 | +86 400 650 58 96  
[customersupport.china@rohde-schwarz.com](mailto:customersupport.china@rohde-schwarz.com)

R&S® is a registered trademark of Rohde & Schwarz GmbH & Co. KG

Trade names are trademarks of the owners

PD 3606.8037.12 | Version 03.00 | November 2014 (ch)

R&S®SMW200A Vector Signal Generator

Data without tolerance limits is not binding | Subject to change

© 2013 - 2014 Rohde & Schwarz GmbH & Co. KG | 81671 Munich, Germany



3606803712